

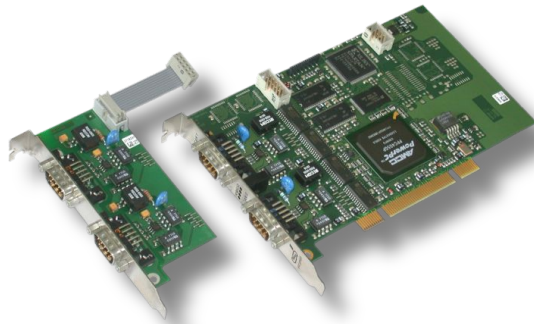

CAN-PCI/405

PCI-CAN Interface



Hardware Manual

to Product C.2023.05, C.2023.07



NOTE

The information in this document has been carefully checked and is believed to be entirely reliable. **esd** makes no warranty of any kind with regard to the material in this document, and assumes no responsibility for any errors that may appear in this document. In particular descriptions and technical data specified in this document may not be constituted to be guaranteed product features in any legal sense.

esd reserves the right to make changes without notice to this, or any of its products, to improve reliability, performance or design.

All rights to this documentation are reserved by **esd**. Distribution to third parties, and reproduction of this document in any form, whole or in part, are subject to **esd**'s written approval.

© 2014 esd electronic system design gmbh, Hannover

esd electronic system design gmbh
Vahrenwalder Str. 207
30165 Hannover
Germany

Phone: +49-511-372 98-0
Fax: +49-511-372 98-68
E-Mail: info@esd.eu
Internet: www.esd.eu

Trademark Notices

CANopen® and CiA® are registered community trademarks of CAN in Automation e.V.
Windows is a registered trademark of Microsoft Corporation in the United States and other countries.
The PICMG® name and logo are registered trademarks of the PCI Industrial Computer Manufacturers Group.

All other trademarks, product names, company names or company logos used in this manual are reserved by their respective owners.

Document file:	I:\Texte\Doku\MANUALS\CAN\PCI405\Englisch\CAN-PCI405_Hardware_en_13.odt
Date of print:	2014-06-25
Document type number:	DOC0800

Hardware version:	CAN-PCI/405 Rev.1.4
--------------------------	---------------------

Document History

The changes in the document listed below affect changes in the hardware as well as changes in the description of the facts, only.

Revision	Chapter	Changes versus previous version	Date
1.2	-	Safety notes inserted	2010-12-01
	1	Sentences concerning optional NVRAM and customer application deleted, new block diagram	
	2	Hardware installation revised	
	2.2	Description of debug interface and serial interface removed, description of CAN2, CAN3 interface corrected	
	2.4	4 CAN interfaces on CAN-PCI/405-4, not optional	
	3.2	Description of options removed	
	3.4	Chapter revised	
	3.5	Sentence removed	
	3.6	Order no. of CAN-PCI/405-2 and CAN-PCI/405-4 changed	
	4.3	Interfaces CAN2, CAN3 only on CAN-PCI/405-4, not optional	
	4.4, 4.5	Description of debug interface and serial interface removed	
1.3	-	Declaration of Conformity inserted	2014-06-25
	-	Safety Instructions revised	
	-	Option DeviceNet is dropped	
	3.4	Entry 'Electrical isolation' revised	
	3.5	Chapter updated	
	7.	Declaration of Conformity updated	
8.	Chapter 'Order Information' moved and revised		

Technical details are subject to change without further notice.



Safety Instructions

- When working with CAN-PCI/405 follow the instructions below and read the manual carefully to protect yourself from injury and the CAN-PCI/405 from damage.
- The device is a built-in component. It is essential to ensure that the device is mounted in a way that cannot lead to endangering or injury of persons or damage to objects.
- The device has to be securely installed in the control cabinet before commissioning.
- Protect the CAN-PCI/405 from dust, moisture and steam.
- Protect the CAN-PCI/405 from shocks and vibrations.
- The CAN-PCI/405 may become warm during normal use. Always allow adequate ventilation around the CAN-PCI/405 and use care when handling.
- Do not operate the CAN-PCI/405 adjacent to heat sources and do not expose it to unnecessary thermal radiation. Ensure an ambient temperature as specified in the technical data.
- Do not use damaged or defective cables to connect the CAN-PCI/405 and follow the CAN wiring hints in chapter: "Correctly Wiring Electrically Isolated CAN Networks".
- In case of damages to the device, which might affect safety, appropriate and immediate measures must be taken, that exclude an endangerment of persons and objects.
- Current circuits which are connected to the device have to be sufficiently protected against hazardous voltage (SELV according to EN 60950-1).
- The CAN-PCI/405 may only be driven by power supply current circuits, that are contact protected.
A power supply, that provides a safety extra-low voltage (SELV or PELV) according to EN 60950-1, complies with this conditions.



Attention !

Electrostatic discharges may cause damage to electronic components.

To avoid this, please perform the steps described on page 7 *before* you touch the CAN-PCI/405, in order to discharge the static electricity from your body.

Qualified Personal

This documentation is directed exclusively towards personal qualified in control and automation engineering. The installation and commissioning of the product may only be carried out by qualified personal, which is authorized to put devices, systems and electric circuits into operation according to the applicable national standards of safety engineering.

Conformity

The CAN-PCI/405 meets the demands of the EU regulations and EMC standards printed in the conformity declaration at the end of this manual.

Intended Use

The intended use of the CAN-PCI/405 is the operation as a PCI-CAN interface board.

The guarantee given by esd does not cover damages which result from improper use, usage not in accordance with regulations or disregard of safety instructions and warnings.

- The CAN-PCI/405 is intended for installation in PCI-systems only.
- The operation of the CAN-PCI/405 in hazardous areas, or areas exposed to potentially explosive materials is not permitted.
- The operation of the CAN-PCI/405 for medical purposes is prohibited.

Service Note

The CAN-PCI/405 does not contain any parts that require maintenance by the user. The CAN-PCI/405 does not require any manual configuration of the hardware.

Disposal

Devices which have become defective in the long run have to be disposed in an appropriate way or have to be returned to the manufacturer for proper disposal. Please, make a contribution to environmental protection.

Table of contents

1. Overview.....	6
1.1 Module Description.....	6
2. Hardware Installation.....	7
2.1 Procedure.....	7
2.2 PCB View with Connectors.....	9
2.3 LEDs and Connectors in the Slot Cover.....	10
2.4 CAN-PCI/405-4 Version with 4 CAN Interfaces.....	11
3. Technical Data.....	12
3.1 General Technical Data.....	12
3.2 Microprocessor and Memory.....	12
3.3 PCI Bus.....	13
3.4 CAN Interface.....	13
3.5 Software Support.....	14
4. Connector Assignments.....	15
4.1 CAN Interface at DSUB9 Connector.....	15
4.2 Connection to Adapter Board (CAN-PCI/405-4 only).....	16
5. Correctly Wiring Electrically Isolated CAN Networks.....	17
5.1 Light Industrial Environment (Single Twisted Pair Cable).....	17
5.1.1 General Rules.....	17
5.1.2 Cabling.....	18
5.1.3 Termination.....	18
5.2 Heavy Industrial Environment (Double Twisted Pair Cable).....	19
5.2.1 General Rules.....	19
5.2.2 Device Cabling.....	20
5.2.3 Termination.....	20
5.3 Electrical Grounding.....	21
5.4 Bus Length.....	21
5.5 Examples for CAN Cables.....	22
5.5.1 Cable for Light Industrial Environment Applications (Two-Wire).....	22
5.5.2 Cable for Heavy Industrial Environment Applications (Four-Wire).....	22
6. CAN Troubleshooting Guide.....	23
6.1 Termination.....	23
6.2 Electrical Grounding.....	24
6.3 Short Circuit in CAN Wiring.....	24
6.4 CAN_H/CAN_L-Voltage.....	24
6.5 CAN Transceiver Resistance Test.....	25
7. Declaration of Conformity.....	26
8. Order Information.....	27

1. Overview

1.1 Module Description

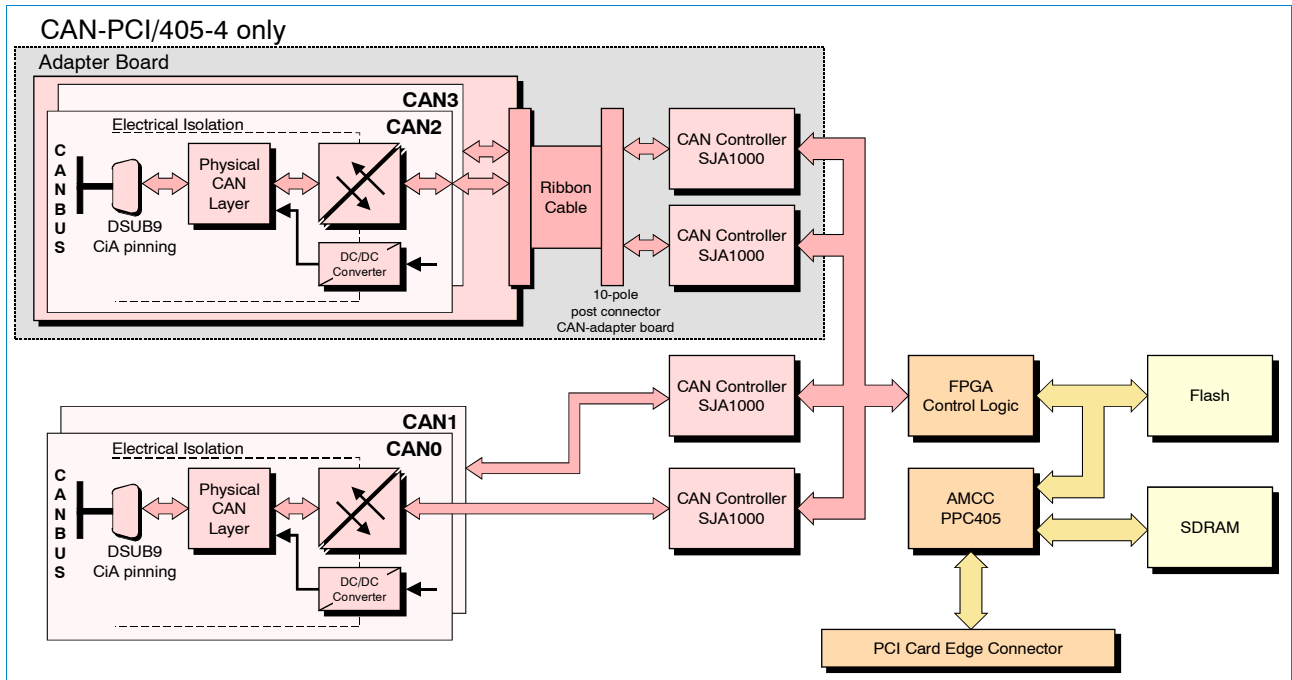

Figure 1: Block circuit diagram

The CAN-PCI/405 is a PC board designed for the PCI bus that supports up to four independent CAN interfaces. In the CAN-PCI/405-2 version two interfaces are placed directly on the board. Furthermore, in the CAN-PCI/405-4 version two additional interfaces are placed on an adapter board.

The IBM PowerPC 405GP with 200 MHz enables a performance of up to 375 MIPS. The board is equipped with 16 Mbyte SDRAM and 1 Mbyte Flash.

The CAN-PCI/405 produces hardware-generated timestamps with a resolution of 1 μ s for all CAN messages.

The CAN-PCI/405-2 provides two and the CAN-PCI/405-4 four ISO 11898 compliant CAN interfaces based on SJA1000 CAN controllers. The CAN interfaces allow a data transfer rate of 1 Mbit/s. The interfaces are electrically isolated from the other potentials.

2. Hardware Installation

2.1 Procedure



Read the safety instructions at the beginning of this document carefully, before you start with the hardware installation!



Danger!

Electric shock risk. Never carry out work while power supply voltage is switched on!



Attention !

Electrostatic discharges may cause damage to electronic components. To avoid this, please perform the following steps *before* you touch the module, in order to discharge the static electricity from your body:

- Switch off the power of your PC, but leave it connected to the mains until you have discharged yourself.
- Please touch the metal case of the PC now to discharge yourself.
- Furthermore, you must avoid contact between your clothes and the CAN-PCI/405.

Procedure:

1. Switch off your computer and all connected peripheral devices (monitor, printer, etc.). Switch off the CAN devices of the net to which the CAN module is to be connected.
2. Discharge your body as described above.
3. Disconnect the power supply of the PC from the mains.
If the computer does not have a flexible mains cable, but is directly connected to mains, disconnect the power supply via the safety fuse and make sure that the fuse cannot switch on again unintentionally (i.e. with caution label).



Danger!

Never carry out work while power supply voltage is switched on!

4. Remove the PC cover.
For further information on this see the manual of your PC.
5. Select an open PCI slot and remove the slot cover of the PC.
The CAN module can be inserted into every PCI slot. Be careful not to insert the board into a slot of another slot type, because this might damage the PC and the board!
6. Insert the CAN module into the selected PCI slot.
Carefully push the board down until it snaps into place.
7. Attach the board.
8. If you are installing the CAN-PCI/405-4 module with 4 CAN interfaces you have to install the adapter board in the PCI slot next to the CAN-PCI/405. Connect the two boards with the included ribbon cable. The cable connectors are reverse-connect protected.

Hardware Installation

9. Replace the PC cover.
10. Connect the CAN wire.
Please note that the CAN bus has to be terminated at both ends! **esd** offers special T-connectors and terminator connectors. Additionally the CAN_GND signal has to be connected to earth at **exactly one** point. For easier wiring the termination connectors are equipped with an earth connector (4.8 mm fast-on, male).
A CAN participant without an electrically isolated interface acts as an earth connection.

The first CAN interface (CAN0) has to be connected via the lower DSUB connector (X1000) and the second CAN interface (CAN1) has to be connected via the upper DSUB connector (X1010) of the CAN-PCI/405.

If you are installing a CAN-PCI/405-4 with four CAN interfaces, you have to connect the third CAN interface (CAN2) via the lower DSUB connector of the adapter board and the fourth CAN interface (CAN3) via the upper DSUB connector of the adapter board. You will find a figure showing the connectors on page 11.

11. Reconnect the power supply of the PC.
12. Switch on the PC, the peripheral devices and the other CAN participants in any order.
13. End of hardware installation.

2.2 PCB View with Connectors

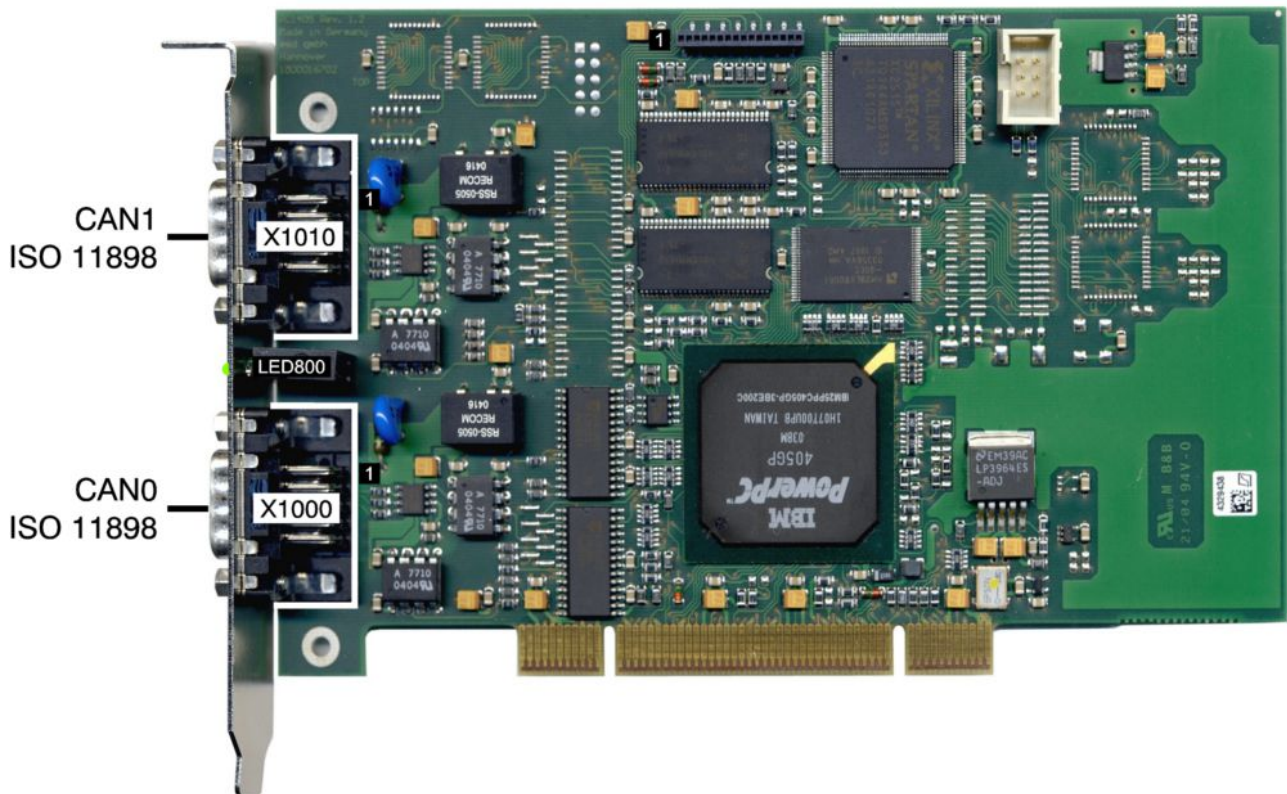

Figure 2: PCB top view of CAN-PCI/405-2

See also page 15 for signal assignment of the CAN connectors.

2.3 LEDs and Connectors in the Slot Cover

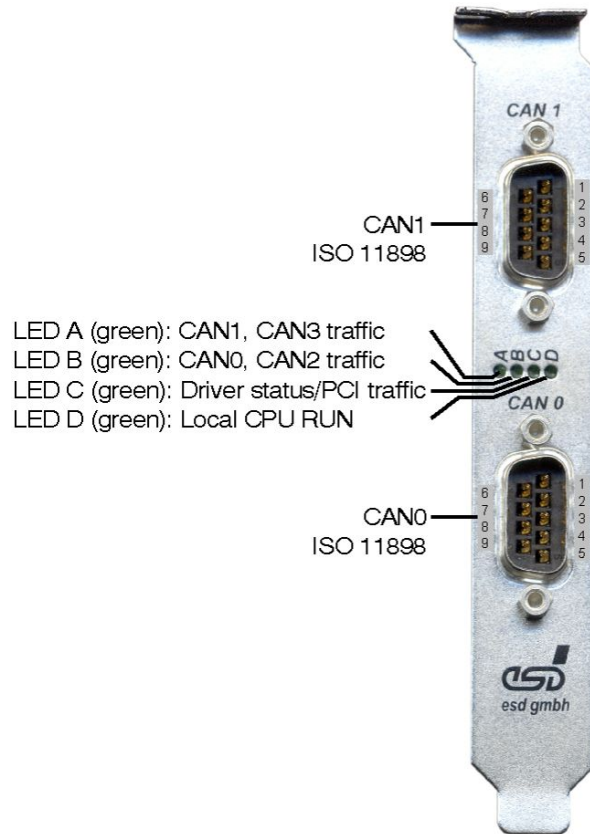

Figure 3: Connectors and LEDs

LED	Function	Description of LED (on)
A	CAN1-, CAN3-traffic	CAN-PCI/405-2: CAN-frames are being received or transmitted on CAN1 CAN-PCI/405-4: CAN-frames are being received or transmitted on CAN1 and/or CAN3
B	CAN0-, CAN2-traffic	CAN-PCI/405-2: CAN-frames are being received or transmitted on CAN0 CAN-PCI/405-4: CAN-frames are being received or transmitted on CAN0 and/or CAN2
C	Driver status	LED off: No driver loaded LED on: Driver loaded LED flickering: Communication with CAN-board
D	Local CPU RUN	Local CPU is in RUN status (LED lights at every access to the SDRAM, therefore the LED can be blinking or permanently on in normal operation)

2.4 CAN-PCI/405-4 Version with 4 CAN Interfaces

In the CAN-PCI/405-4 version, the board is equipped with four CAN interfaces.

This module type is equipped with two additional SJA1000 CAN controllers. The physical layer of the additional CAN nets is placed at a separate adapter board. The adapter board has to be mounted close to the CAN-PCI/405 and has to be connected via the ribbon cable that is contained in the scope of delivery.

The additional physical interfaces CAN2 and CAN3 are designed identical to the physical interfaces of CAN0 and CAN1.

The four-CAN version CAN-PCI/405-4 has the order number: C.2023.07
 It is not possible to connect the adapter board to a CAN-PCI/405-2 (order no.: C.2023.05).

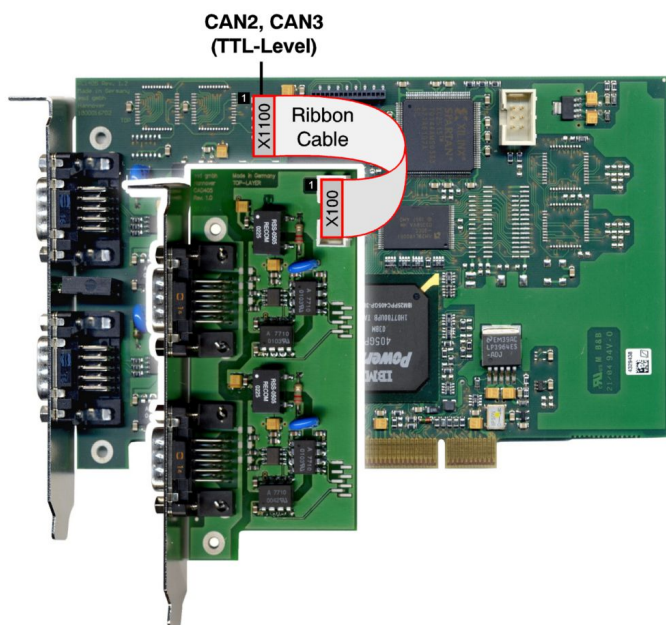

Figure 4: Connection of the adapter board via ribbon cable

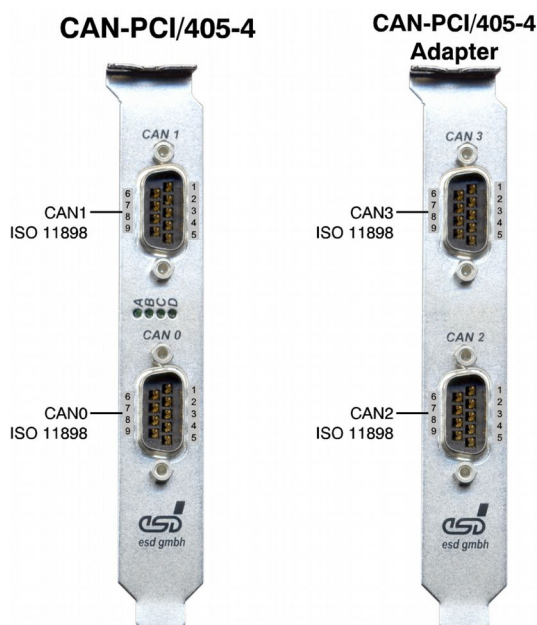

Figure 5: CAN channel assignment to the connectors

3. Technical Data

3.1 General Technical Data

Power supply voltage	<p>supplied by PCI bus, nominal voltage: 5 V ±5%, 3.3 V ±5%, typical current consumption for 2x CAN (max., at 20°C): 0,62 A at 3,3 V 0,13 A at 5 V</p>
Connectors	<p>PCI bus - card edge (X100) CAN0 - DSUB9/male (X1000) CAN1 - DSUB9/male (X1010)</p> <p>The following connectors are only equipped for programming and service: debug interface - 10-pole SMD female con. (X720) serial interface (TTL) - 6-pole post connector (X710)</p> <p>CAN-PCI/405-4 only: Connector to adapter board for CAN net 2 and CAN net 3 - 10-pole post connector (X1100)</p> <p>The following connectors are on the adapter board CAN2 - DSUB9/male (P130) CAN3 - DSUB9/male (P170)</p> <p>Connector on the adapter board for the connection of the CAN-PCI/405-4 via ribbon cable - 10-pin post connector (X100)</p>
Temperature range	0...50 °C ambient temperature
Humidity	max. 90%, non-condensing
Dimensions	164.64 mm x 106.68 mm (without slot cover panel and CAN connectors)
Weight	<200 g

Table 1: General data of the module

3.2 Microprocessor and Memory

CPU	PowerPC 405GP, 200 MHz, 32 bit
Flash	1 MB Flash
SDRAM	4 M x 32 bit SDRAM (16 Mbyte)

Table 2: Microprocessor and memory

3.3 PCI Bus

Host bus	PCI in compliance with PCI Local Bus Spec. 2.2
PCI data bus	32 bit
Controller	PPC405GP
Interrupt	interrupt signal A
Slot position	no restrictions for the slot position
Board dimension	PCI short card
Connector	PCI card edge connector

Table 3: PCI bus data

3.4 CAN Interface

Number of CAN interfaces	CAN-PCI/405-2: 2 CAN-PCI/405-4: 4 (2 and 2 additional CAN interfaces at adapter board)
CAN controller	SJA1000, acc. to ISO 11898-1 (CAN 2.0 A/B)
Physical Layer	Physical layer according to ISO 11898-2, transmission rate is programmable from 10 Kbit/s to 1 Mbit/s
Bus termination	terminating resistor has to be set externally, if required
Electrical isolation of the CAN interface against other units	both CAN interfaces are electrically isolated via optocouplers and DC/DC-converters against each other and against the PCI bus potentials

Table 4: Data of the CAN interface

3.5 Software Support

Device drivers for Windows® and Linux® and real-time operating systems are available (see 'Order Information', page 27).

The CANopen software package is available for Windows, Linux, QNX® and RTX.
J1939 Stack is available as higher layer protocol for Windows, Linux and RTX.

For detailed information about the driver availability for your special operating system, please contact our sales team: sales@esd.eu

Additional free-of-charge esd CAN tools for Windows offer efficient setup and analysis of CAN applications and networks.

The software installation and the software drivers are described in the manual:

NTCAN-API: Application Developers Manual

NTCAN-API: Driver Installation Guide

esd-order No.: C.2001.21

4. Connector Assignments

4.1 CAN Interface at DSUB9 Connector

The assignment of the signals to the connector pins is the same for all CAN interfaces. All connectors are 9-pole DSUBs with male contacts.

CAN-PCI/405-2 and CAN-PCI/405-4:

CAN0 (X1000), CAN1 (X1010)

CAN-PCI/405-4 (connectors on the adapter board):

CAN2 (P130), CAN3 (P170)

Device connector: 9-pin DSUB connector, male

Pin Position:

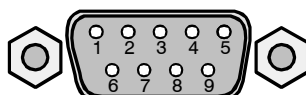

Pin Assignment:

Signal	Pin	Signal
(CAN_GND)	6	1 reserved
CAN_H		2 CAN_L
reserved	8	3 CAN_GND
reserved		4 reserved
	9	5 Shield

Signal Description:

CAN_L, CAN_H ...	CAN signal lines
CAN_GND ...	reference potential of the local CAN physical layer
(CAN-GND)...	optional CAN_GND
Shield ...	connected to computer case via slot cover panel
reserved ...	reserved for future applications, do not connect!

4.2 Connection to Adapter Board (CAN-PCI/405-4 only)

The CAN-PCI/405-4 board is equipped with the 10-pole post connector (X1100) for the connection of the adapter board via a ribbon cable.

The signals of CAN2 and CAN3 are TTL level signals.

Signal	Pin		Signal
+5V	1	2	Tx0-CAN2*
Tx1-CAN2*	3	4	Rx0-CAN2*
Rx1-CAN2*	5	6	Tx0-CAN3*
Tx1-CAN3*	7	8	Tx0-CAN3*
Rx1-CAN3*	9	10	GND

10-pole post connector

Signal Description:

Tx0-CAN2*, Rx0-CAN2*,
Tx1-CAN2*, Rx1-CAN2*... CAN signals (TTL-level) of the interface CAN2

Tx0-CAN3*, Rx0-CAN3*,
Tx1-CAN3*, Rx1-CAN3*... CAN signals (TTL-level) of the interface CAN3

+5V, GND ... power supply of the adapter board

5. Correctly Wiring Electrically Isolated CAN Networks

For the CAN wiring all applicable rules and regulations (EC, DIN), e.g. regarding electromagnetic compatibility, security distances, cable cross-section or material, have to be met.

5.1 Light Industrial Environment (*Single Twisted Pair Cable*)

5.1.1 General Rules

i	<p>Note: esd grants the EC Conformity of the product, if the CAN wiring is carried out with at least single shielded single twisted pair cables that match the requirements of ISO 11898-2. Single shielded <i>double</i> twisted pair cable wiring as described in chapter 5.2. ensures the EC Conformity as well.</p>
----------	---

The following **general rules** for CAN wiring with single shielded *single* twisted pair cable must be followed:

1	A cable type with a wave impedance of about $120\ \Omega \pm 10\%$ with an adequate wire cross-section ($0.22\ \text{mm}^2$) has to be used. The voltage drop over the wire has to be considered!
2	For light industrial environment use at least a two-wire CAN cable. Connect <ul style="list-style-type: none"> • the two twisted wires to the data signals (CAN_H, CAN_L) and • the cable shield to the reference potential (CAN_GND)!
3	The reference potential CAN_GND has to be connected to the functional earth (FE) at exactly one point.
4	A CAN net must not branch (exception: short cable stubs) and has to be terminated with the characteristic impedance of the line (generally $120\ \Omega \pm 10\%$) at both ends (between the signals CAN_L and CAN_H and not at GND)!
5	Keep cable stubs as short as possible ($l < 0.3\ \text{m}$)!
6	Select a working combination of bit rate and cable length.
7	Keep away cables from disturbing sources. If this cannot be avoided, double shielded wires are recommended.

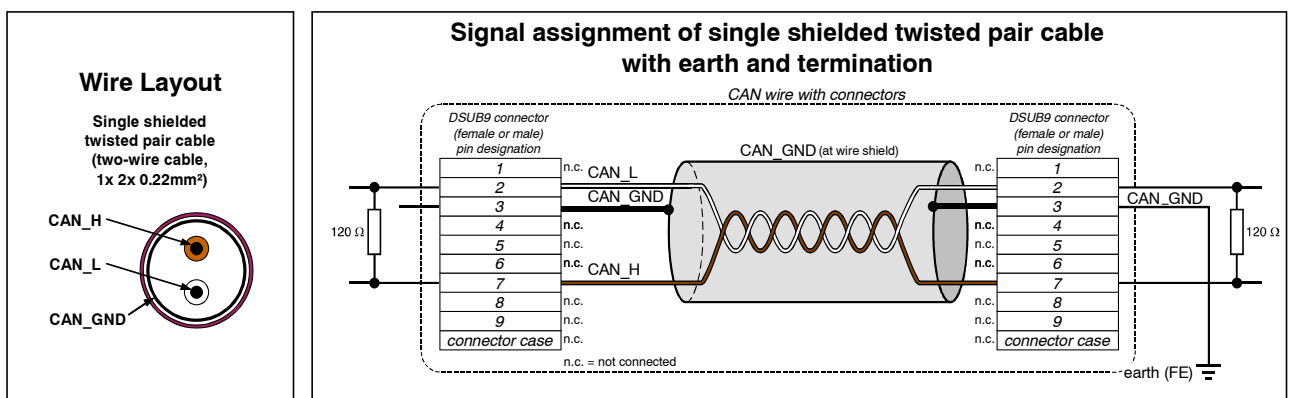

Figure 6: CAN wiring for light industrial environment

5.1.2 Cabling

- for devices which have only one CAN connector per net use T-connector and stub (shorter than 0.3 m) (available as accessory)

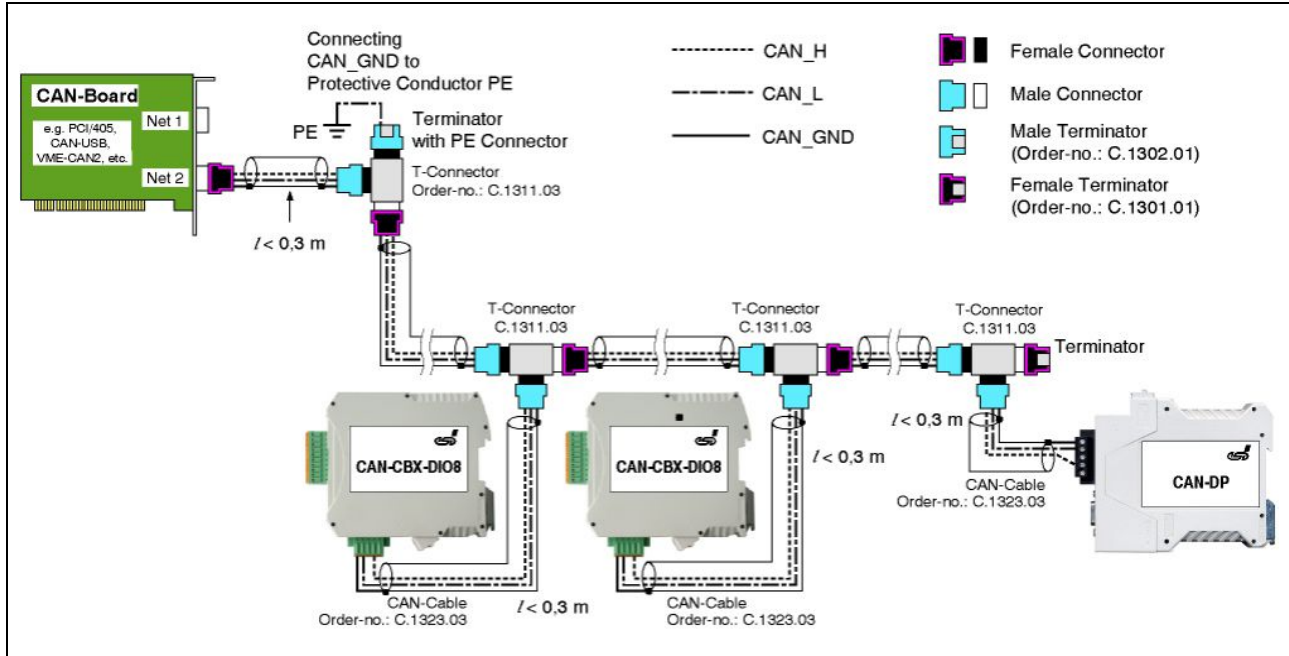

Figure 7: Example for proper wiring with single shielded single twisted pair wires

5.1.3 Termination

- If the used CAN interface is not equipped with an integrated CAN termination and it is at an end of the bus, use external termination plugs.
- 9-pin DSUB-termination connectors with male and female contacts and earth terminal are available as accessories

5.2 Heavy Industrial Environment (*Double Twisted Pair Cable*)

5.2.1 General Rules

The following **general rules** for the CAN wiring with single shielded *double* twisted pair cable must be followed:

1	A cable type with a wave impedance of about $120\ \Omega \pm 10\%$ with an adequate wire cross-section ($0.22\ \text{mm}^2$) has to be used. The voltage drop over the wire has to be considered!
2	For heavy industrial environment use a four-wire CAN cable. Connect <ul style="list-style-type: none"> • two twisted wires to the data signals (CAN_H, CAN_L) and • the other two twisted wires to the reference potential (CAN_GND) and • the cable shield to functional earth (FE) at least at one point!
3	The reference potential CAN_GND has to be connected to the functional earth (FE) at exactly one point.
4	A CAN bus line must not branch (exception: short cable stubs) and has to be terminated with the characteristic impedance of the line (generally $120\ \Omega \pm 10\%$) at both ends (between the signals CAN_L and CAN_H and not at GND)!
5	Keep cable stubs as short as possible ($l < 0.3\ \text{m}$)!
6	Select a working combination of bit rate and cable length.
7	Keep away CAN cables from disturbing sources. If this can not be avoided, double shielded cables are recommended.

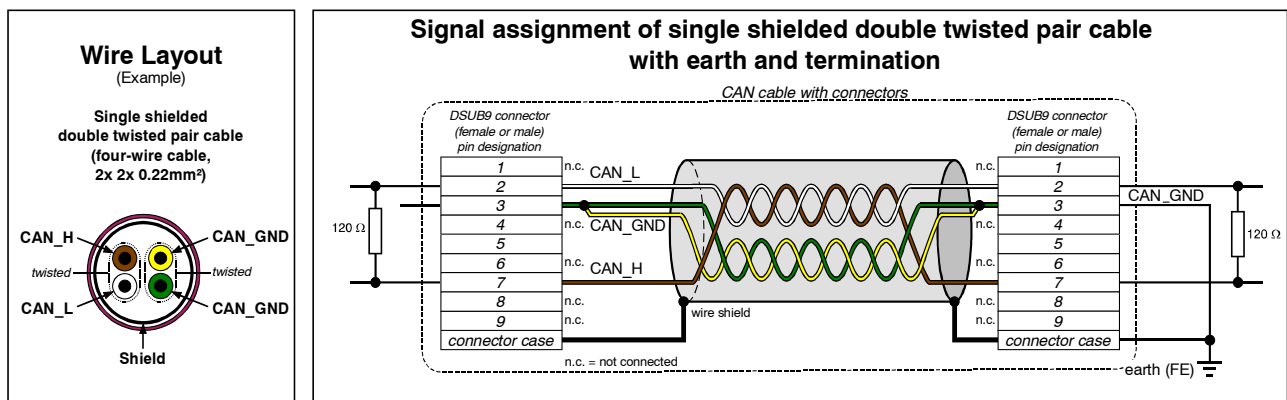



Figure 8: CAN wiring for heavy industrial environment

5.2.2 Device Cabling

- To connect CAN devices which are equipped with one CAN connector per net, use T-connectors and cable stubs (shorter than 0.3 m).

 **Attention:**
If single shielded *double* twisted pair cables are used, realize the T-connections by means of connectors that support connection of two CAN cables at one connector where the cable's shield is looped through e.g. DSUB9 connector from ERNI (ERBIC CAN BUS MAX, order no.:154039).

The usage of esd's T-connector type C.1311.03 is not recommended for single shielded *double* twisted pair cables because the shield potential of the conductive DSUB housing is not looped through this T-connector type.

Furthermore, mixed use of single twisted and double twisted cables should be avoided!

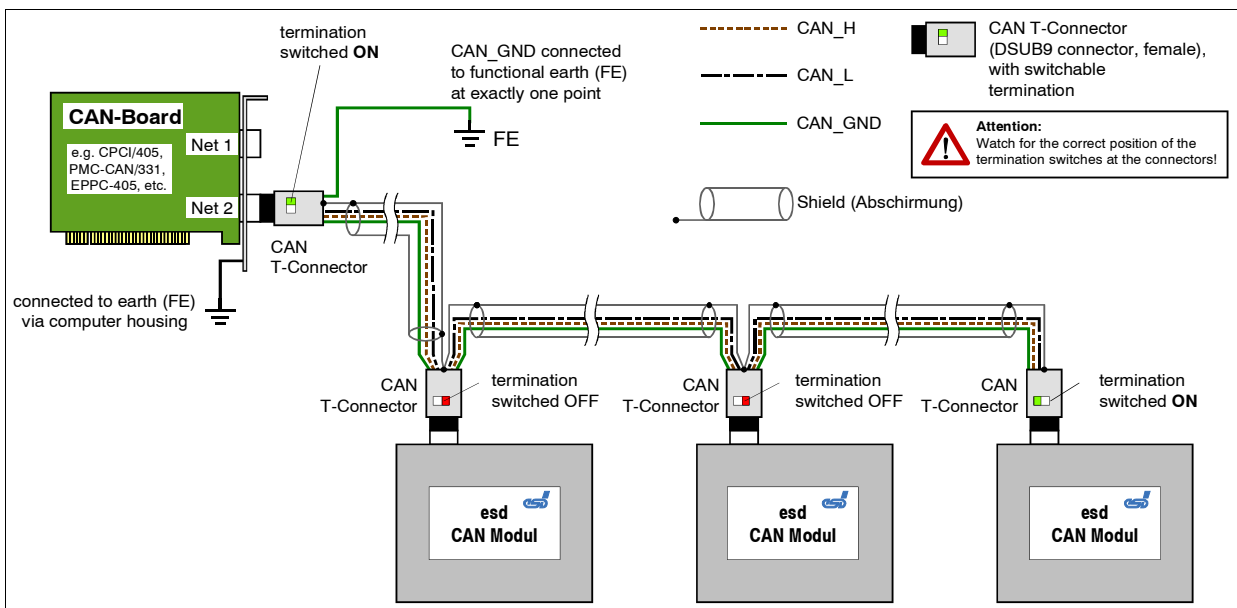

Figure 9: Example for proper wiring with single shielded double twisted pair cables

5.2.3 Termination

- If the used CAN interface is not equipped with an integrated CAN termination and it is at an end of the bus, use external termination plugs.
- A 9-pin DSUB-connector with integrated switchable termination resistor can be ordered e.g. from ERNI (ERBIC CAN BUS MAX, female contacts, order no.:154039).

5.3 Electrical Grounding

- For CAN devices with electrical isolation the CAN_GND must be connected between the CAN devices!
- CAN_GND has to be connected to the earth potential (FE) at **exactly one** point of the network!
- Each *CAN interface with electrical connection to earth potential* acts as an earthing point. For this reason do not connect more than one *CAN device with electrical connection to earth potential!*
- Earthing can e.g. be made at a connector/T-connector.

5.4 Bus Length

- Optical couplers are delaying the CAN signals. esd modules typically reach a wire length of 37 m at 1 Mbit/s within a closed net without impedance disturbances like e.g. cable stubs >> 0.3 m.

Bit rate [Kbits/s]	Typical values of reachable wire length with esd interface l_{max} [m]	CiA recommendations (07/95) for reachable wire lengths l_{min} [m]
1000	37	25
800	59	50
666.6	80	-
500	130	100
333.3	180	-
250	270	250
166	420	-
125	570	500
100	710	650
83.3	850	-
66.6	1000	-
50	1400	1000
33.3	2000	-
20	3600	2500
12.5	5400	-
10	7300	5000

Table 5: Recommended cable lengths at typical bit rates (with esd-CAN interfaces)



Note: Please note the recommendations according to ISO 11898 for the selection of the cross section of the wire depending of the wire length.

5.5 Examples for CAN Cables

5.5.1 Cable for Light Industrial Environment Applications (Two-Wire)

Manufacturer	Cable Type
U.I. LAPP GmbH Schulze-Delitzsch-Straße 25 70565 Stuttgart Germany www.lappkabel.com	e.g. UNITRONIC ®-BUS CAN UL/CSA (1x 2x 0.22) (UL/CSA approved) Part No.: 2170260 UNITRONIC ®-BUS-FD P CAN UL/CSA (1x 2x 0.25) (UL/CSA approved) Part No.: 2170272
ConCab GmbH Äußerer Eichwald 74535 Mainhardt Germany www.concab.de	e. g. BUS-PVC-C (1x 2x 0.22 mm ²) Order No.: 93 022 016 (UL appr.) BUS-Schleppflex-PUR-C (1x 2x 0.25 mm ²) Order No.: 94 025 016 (UL appr.)

5.5.2 Cable for Heavy Industrial Environment Applications (Four-Wire)

Manufacturer	Cable Type
U.I. LAPP GmbH Schulze-Delitzsch-Straße 25 70565 Stuttgart Germany www.lappkabel.com	e.g. UNITRONIC ®-BUS CAN UL/CSA (2x 2x 0.22) (UL/CSA approved) Part No.: 2170261 UNITRONIC ®-BUS-FD P CAN UL/CSA (2x 2x 0.25) (UL/CSA approved) Part No.: 2170273
ConCab GmbH Äußerer Eichwald 74535 Mainhardt Germany www.concab.de	e. g. BUS-PVC-C (2x 2x 0.22 mm ²) Order No.: 93 022 026 (UL appr.) BUS-Schleppflex-PUR-C (2x 2x 0.25 mm ²) Order No.: 94 025 026 (UL appr.)

	<p>Note: Configured CAN cables can be ordered from esd.</p>
---	---

6. CAN Troubleshooting Guide

The CAN Troubleshooting Guide is a guide to find and eliminate the most frequent hardware-error causes in the wiring of CAN-networks.

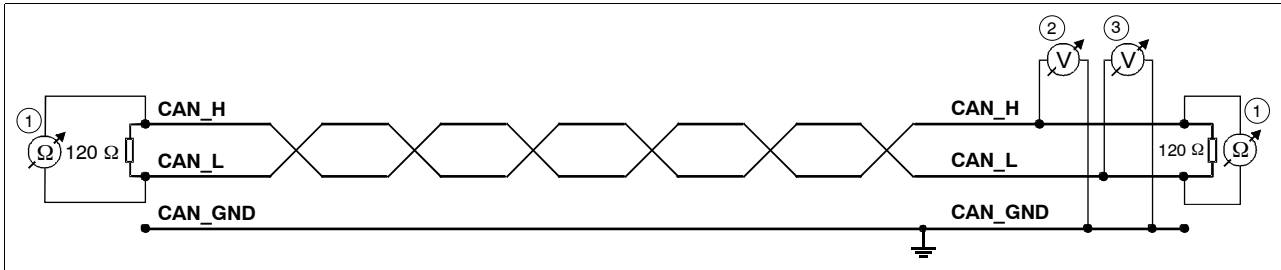

Figure 10: Simplified diagram of a CAN network

6.1 Termination

The termination is used to match impedance of a node to the impedance of the transmission line being used. When impedance is mismatched, the transmitted signal is not completely absorbed by the load and a portion is reflected back into the transmission line. If the source, transmission line and load impedance are equal these reflections are eliminated. This test measures the series resistance of the CAN data pair conductors and the attached terminating resistors.

To test it, please

1. Turn off all power supplies of the attached CAN nodes.
2. Measure the DC resistance between CAN_H and CAN_L at the ends of the network ① (see figure above) and at the centre of the network (if the network cable consists of more than one line section).

The measured value should be between 50 Ω and 70 Ω. The measured value should be nearly the same at each point of the network.

If the value is below 50 Ω, please make sure that:

- there is no short circuit between CAN_H and CAN_L wiring
- there are not more than two terminating resistors
- the nodes do not have faulty transceivers.

If the value is higher than 70 Ω, please make sure that:

- there are no open circuits in CAN_H or CAN_L wiring
- your bus system has two terminating resistors (one at each end) and that they are 120 Ω each.

6.2 Electrical Grounding

The CAN_GND of the CAN network has to be connected to the functional earth potential (FE) at only **one** point. This test will indicate if the CAN_GND is grounded in several places.

To test it, please

1. Disconnect the CAN_GND from the earth potential (FE).
2. Measure the DC resistance between CAN_GND and earth potential (see figure on the right).
3. Connect CAN_GND to earth potential.

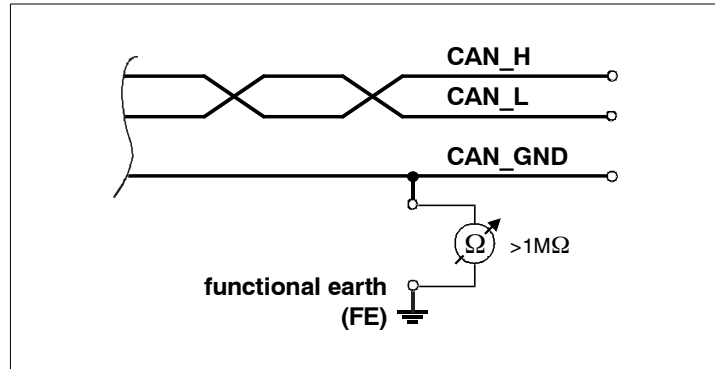

Figure 11: Simplified schematic diagram of ground test measurement

The resistance should be higher than 1 MΩ. If it is lower, please search for additional grounding of the CAN_GND wires.

6.3 Short Circuit in CAN Wiring

A CAN bus might possibly still be able to transmit data if there is a short circuit between CAN_GND and CAN_L, but the error rate will increase strongly. Make sure that there is no short circuit between CAN_GND and CAN_L!

6.4 CAN_H/CAN_L-Voltage

Each node contains a CAN transceiver that outputs differential signals. When the network communication is idle the CAN_H and CAN_L voltages are approximately 2.5 volts. Faulty transceivers can cause the idle voltages to vary and disrupt network communication.

To test for faulty transceivers, please

1. Turn on all supplies.
2. Stop all network communication.
3. Measure the DC voltage between CAN_H and GND ② (see figure above).
4. Measure the DC voltage between CAN_L and GND ③ (see figure above).

Normally the voltage should be between 2.0 V and 4.0 V.

If it is lower than 2.0 V or higher than 4.0 V, it is possible that one or more nodes have faulty transceivers. For a voltage lower than 2.0 V please check CAN_H and CAN_L conductors for continuity. For a voltage higher than 4.0 V, please check for excessive voltage.

To find the node with a faulty transceiver please test the CAN transceiver resistance (see below).

6.5 CAN Transceiver Resistance Test

CAN transceivers have one circuit that controls CAN_H and another circuit that controls CAN_L. Experience has shown that electrical damage to one or both of the circuits may increase the leakage current in these circuits.

To measure the current leakage through the CAN circuits, please use an resistance measuring device and:

1. Switch off the node and disconnect it from the network ④ (see figure below).
2. Measure the DC resistance between CAN_H and CAN_GND ⑤ (see figure below).
3. Measure the DC resistance between CAN_L and CAN_GND ⑥ (see figure below).

The measured resistance has to be about 500 k Ω for each signal. If it is much lower, the CAN transceiver it is probably faulty.

Another sign for a faulty transceiver is a very high deviation between the two measured input resistance (>> 200%).

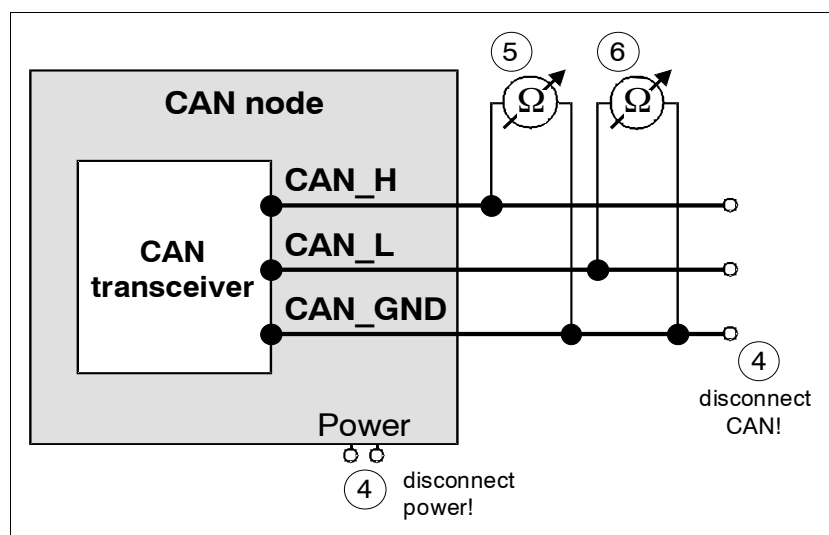

Figure 12: Measuring the internal resistance of CAN transceivers

7. Declaration of Conformity

EG-KONFORMITÄTSERKLÄRUNG EC DECLARATION OF CONFORMITY



Adresse **esd electronic system design gmbh**
Address **Vahrenwalder Str. 207**
30165 Hannover
Germany

esd erklärt, dass das Produkt
esd declares, that the product

CAN-PCI/405-2
CAN-PCI/405-4

Typ, Modell, Artikel-Nr.
Type, Model, Article No.

C.2023.05
C.2023.07

die Anforderungen der Normen
fulfills the requirements of the standards

EN 61000-6-2:2005,
EN 61000-6-3:2007+A1:2011

gemäß folgendem Prüfbericht erfüllt.
according to test certificate.

H-K00-0331-08

Das Produkt entspricht damit der EG-Richtlinie „EMV“
Therefore the product corresponds to the EC-Directive 'EMC'

2004/108/EG

Das Produkt entspricht der EG-Richtlinie „RoHS“
The product corresponds to the EC-Directive 'RoHS'

2011/65/EU

Diese Erklärung verliert ihre Gültigkeit, wenn das Produkt nicht den Herstellerunterlagen entsprechend eingesetzt und betrieben wird, oder das Produkt abweichend modifiziert wird.
This declaration loses its validity if the product is not used or run according to the manufacturer's documentation or if non-compliant modifications are made.

Name / Name T. Bielert
Funktion / Title QM-Beauftragter / Quality Management Representative
Datum / Date Hannover, 2014-06-12

Rechtsgültige Unterschrift / authorized signature

8. Order Information

Type	Properties	Order No.
CAN-PCI/405-2	1x CAN, ISO 11898	C.2023.05
CAN-PCI/405-4	2x CAN, ISO 11898	C.2023.07
CAN layer 2 drivers for Windows and Linux are included in delivery.		
Software*		
CAN-DRV LCD QNX	CAN-driver object licence for QNX incl. CD-ROM	C.1101.32
CAN-DRV LCD RTX	CAN-driver object licence for RTX incl. CD-ROM	C.1101.35
CAN-DRV LCD OnTime RTOS	CAN-driver object licence for OnTimeRTOS incl. CD-ROM	C.1101.45
CANopen-LCD Windows/Linux	CANopen license for Linux and Windows incl. CD-ROM	C.1101.06
CANopen-LCD QNX	CANopen license QNX incl. CD-ROM	C.1101.17
CANopen-LCD RTX	CANopen license for RTX incl. CD-ROM	C.1101.16
J1939 Stack for Windows	J1939 Stack for esd-CAN-Hardware, includes Windows-XP object code, J1939 Simulation Tool, esd CAN Windows driver license	C.1130.10
J1939 Stack for Linux	J1939 Stack for esd-CAN-Hardware, includes Linux object code, esd CAN driver license for Linux	C.1130.11
J1939 Stack for RTX (Object)	J1939 Stack for esd CAN-Hardware - RTX object code - includes esd CAN driver licence for RTX	C.1130.12

* For detailed information about the driver availability of your special operating system, please contact our sales team.

Table 6: Order information

PDF Manuals

Manuals are available in English and usually in German as well. For availability of English manuals see table below.

Please download the manuals as PDF documents from our esd website www.esd.eu for free.

Order Information

Manuals		Order No.
CAN-PCI/405-ME	Hardware manual in English	C.2023.21
CAN-API-ME	NTCAN-API: Application Developers Manual NTCAN-API: Driver Installation Guide	C.2001.21
CANopen-ME	CANopen manuals in English	C.2002.21

Table 7: Available manuals

Printed Manuals

If you need a printout of the manual additionally, please contact our sales team: sales@esd.eu for a quotation. Printed manuals may be ordered for a fee.