



CAN-PCI/400

PCI-CAN Interface



CAN-PCI/400-2 (C.2048.04)

Hardware Manual

to Product C.2048.04, C.2048.06



NOTE

The information in this document has been carefully checked and is believed to be entirely reliable. **esd** makes no warranty of any kind with regard to the material in this document, and assumes no responsibility for any errors that may appear in this document. In particular descriptions and technical data specified in this document may not be constituted to be guaranteed product features in any legal sense.

esd reserves the right to make changes without notice to this, or any of its products, to improve reliability, performance or design.

All rights to this documentation are reserved by **esd**. Distribution to third parties, and reproduction of this document in any form, whole or in part, are subject to **esd**'s written approval.

© 2015 esd electronic system design gmbh, Hannover

esd electronic system design gmbh
Vahrenwalder Str. 207
30165 Hannover
Germany

Phone: +49-511-372 98-0

Fax: +49-511-372 98-68

E-Mail: info@esd.eu

Internet: www.esd.eu



This manual contains important information and instructions on safe and efficient handling of the CAN-PCI/400. Carefully read this manual before commencing any work and follow the instructions.

The manual is a product component, please retain it for future use.

Trademark Notices

CANopen® and CiA® are registered community trademarks of CAN in Automation e.V.

Windows is a registered trademark of Microsoft Corporation in the United States and other countries.

The PICMG® name and logo are registered trademarks of the PCI Industrial Computer Manufacturers Group.

All other trademarks, product names, company names or company logos used in this manual are reserved by their respective owners.

Document file:	I:\Texte\Doku\MANUALS\CAN\PCI\CAN-PCI400\Englisch\CAN-PCI400_Hardware_en_11.odt
Date of print:	2015-12-08
Document type number:	DOC0800

Hardware version:	CAN-PCI/400 Rev. 1.0
--------------------------	----------------------

Document History

The changes in the document listed below affect changes in the hardware as well as changes in the description of the facts, only.

Revision	Chapter	Changes versus previous version	Date
1.0	-	First English version	2012-03-20
1.1	-	Safety messages and instructions revised	2015-12-08
	2.	Chapter revised	
	8.	Declaration of conformity new	
	9.	Order information revised	

Technical details are subject to change without further notice.

Classification of Warning Messages and Safety Instructions

This manual contains noticeable descriptions, warning messages and safety instructions, which you must follow to avoid personal injuries or death and property damage.



This is the safety alert symbol.

It is used to alert you to potential personal injury hazards. Obey all safety messages and instructions that follow this symbol to avoid possible injury or death.

DANGER, WARNING, CAUTION

Depending on the hazard level the signal words DANGER, WARNING or CAUTION are used to highlight safety instructions and warning messages. These messages may also include a warning relating to property damage.



DANGER

Danger statements indicate a hazardous situation which, if not avoided, will result in death or serious injury.



WARNING

Warning statements indicate a hazardous situation that, if not avoided, could result in death or serious injury.



CAUTION

Caution statements indicate a hazardous situation that, if not avoided, could result in minor or moderate injury.

NOTICE

Notice statements are used to notify people on hazards that could result in things other than personal injury, like property damage.



NOTICE

This NOTICE statement indicates that the device contains components sensitive to electrostatic discharge.



NOTICE

This NOTICE statement contains the general mandatory sign and gives information that must be heeded and complied with for a safe use.

INFORMATION



INFORMATION

Notes to point out something important or useful.



Safety Instructions

- When working with the CAN-PCI/400 follow the instructions below and read the manual carefully to protect yourself from injury and the CAN-PCI/400 from damage.
- The device is a built-in component. It is essential to ensure that the device is mounted in a way that cannot lead to endangering or injury of persons or damage to objects.
- Do not use damaged or defective cables to connect the CAN-PCI/400 and follow the CAN wiring hints in chapter: "Correct Wiring of Electrically Isolated CAN Networks".
- In case of damages to the device, which might affect safety, appropriate and immediate measures must be taken, that exclude an endangerment of persons and domestic animals and property.
- Current circuits which are connected to the device have to be sufficiently protected against hazardous voltage (SELV according to EN 60950-1).
- The CAN-PCI/400 may only be driven by power supply current circuits, that are contact protected. A power supply, that provides a safety extra-low voltage (SELV) according to EN 60950-1, complies with this conditions.

- The device has to be securely installed in the control cabinet before commissioning.
- Protect the CAN-PCI/400 from dust, moisture and steam.
- Protect the CAN-PCI/400 from shocks and vibrations.
- The CAN-PCI/400 may become warm during normal use. Always allow adequate ventilation around the CAN-PCI/400 and use care when handling.
- Do not operate the CAN-PCI/400 adjacent to heat sources and do not expose it to unnecessary thermal radiation. Ensure an ambient temperature as specified in the technical data.



DANGER

Hazardous Voltage - **Risk of electric shock** due to unintentional contact with uninsulated live parts with high voltages inside of the system into which the CAN-PCI/400 is to be integrated.

- Disconnect all hazardous voltages (mains voltage) before opening the system.
- Ensure the absence of voltage before starting any electrical work



NOTICE

Electrostatic discharges may cause damage to electronic components.

To avoid this, perform the steps described on page 10 *before* you touch the CAN-PCI/400, in order to discharge the static electricity from your body.

Qualified Personal

This documentation is directed exclusively towards personal qualified in control and automation engineering.

The installation and commissioning of the product may only be carried out by qualified personal, which is authorized to put devices, systems and electric circuits into operation according to the applicable national standards of safety engineering.

Conformity

The CAN-PCI/400-2 meets the demands of the EU regulations and EMC standards printed in the conformity declaration at the end of this manual.

Intended Use

The intended use of the CAN-PCI/400 is the operation as a PCI CAN interface for PCs.

The guarantee given by esd does not cover damages which result from improper use, usage not in accordance with regulations or disregard of safety instructions and warnings.

- The CAN-PCI/400 is intended for installation in a PCI slot of an industrial or home computer only.

- The operation of the CAN-PCI/400 in hazardous areas, or areas exposed to potentially explosive materials is not permitted.
- The operation of the CAN-PCI/400 for medical purposes is prohibited.

Service Note

The CAN-PCI/400 does not contain any parts that require maintenance by the user. The CAN-PCI/400 does not require any manual configuration of the hardware.

Disposal

Devices which have become defective in the long run have to be disposed in an appropriate way or have to be returned to the manufacturer for proper disposal. Please, make a contribution to environmental protection.

Abbreviations

API	Application Programming Interface
CAN	Controller Area Network
CPU	Central Processing Unit
CiA	CAN in Automation
I/O	Input/Output
esdACC	esd Advanced CAN Core

Table of contents

Safety Instructions.....	5
1. Overview.....	8
1.1 Description of the Module.....	8
1.2 PCB View with Connectors.....	9
2. Hardware Installation.....	10
2.1 CAN-PCI/400-4 Version with 4 CAN Interfaces.....	12
3. Front Panel View with LED-Display.....	13
3.1 Additional LEDs on CAN-PCI/400-4 Adapter Board.....	14
4. Technical Data.....	15
4.1 General Technical Data.....	15
4.2 PCI-Bus.....	15
4.3 CAN Interface.....	16
4.4 Software Support.....	16
5. Connector Assignments.....	17
5.1 CAN.....	17
6. Correct Wiring of Electrically Isolated CAN Networks.....	18
6.1 Standards concerning CAN Wiring.....	18
6.2 Light Industrial Environment (Single Twisted Pair Cable).....	19
6.2.1 General Rules.....	19
6.2.2 Cabling.....	20
6.2.3 Termination.....	20
6.3 Heavy Industrial Environment (Double Twisted Pair Cable).....	21
6.3.1 General Rules.....	21
6.3.2 Device Cabling.....	22
6.3.3 Termination.....	22
6.4 Electrical Grounding.....	23
6.5 Bus Length.....	23
6.6 Examples for CAN Cables.....	24
6.6.1 Cable for light industrial Environment Applications (Two-Wire).....	24
6.6.2 Cable for heavy industrial Environment Applications (Four-Wire).....	24
7. CAN Troubleshooting Guide.....	25
7.1 Termination.....	25
7.2 Electrical Grounding.....	26
7.3 Short Circuit in CAN Wiring.....	26
7.4 CAN_H/CAN_L-Voltage.....	26
7.5 CAN Transceiver Resistance Test.....	27
7.6 Support by esd.....	27
8. Declaration of Conformity.....	28
9. Order Information.....	29

1. Overview

1.1 Description of the Module

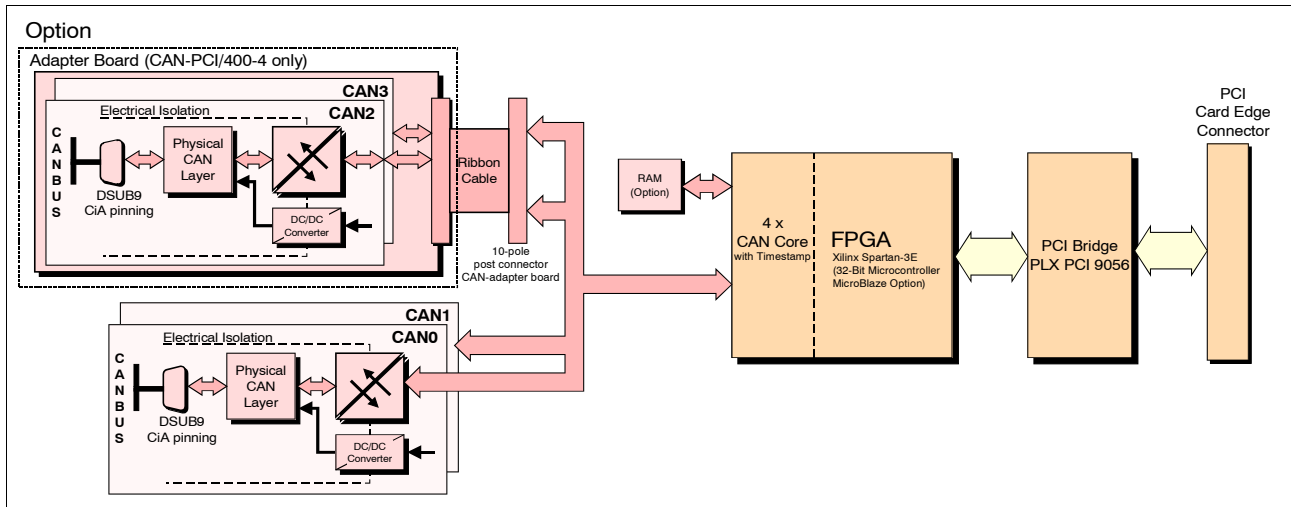

Figure 1: Block circuit diagram of CAN-PCI/400

The CAN-PCI/400 is a PC board designed for the PCI bus that features two (CAN-PCI/400-2) or optionally four (CAN-PCI/400-4) electrically isolated CAN High-Speed interfaces according to ISO 11898-2. CAN-PCI/400-4 comes with two additional CAN interfaces via a separate slot bracket.

The independent CAN nets acc. to ISO 11898-1 are driven by the esdACC (esd Advanced CAN Core) implemented in the Xilinx® Spartan®-3E FPGA. Controlled by the FPGA the CAN-PCI/400 supports bus mastering as an initiator, meaning that it is capable of initiating write cycles to the host CPU's RAM independent of the CPU or the system DMA controller. This results in a reduction of overall latency on servicing I/O transactions in particular at higher data rates and reduced host CPU load.

The CAN-PCI/400 provides high resolution hardware timestamps.
CAN Error injection on request.

CAN layer 2 (NTCAN-API) software drivers are available for Windows®, VxWorks®, QNX®, RTX® and Linux® supporting up to 24 CAN nets. Drivers for other operating systems are available on request. The CANopen software package is available for Windows, Linux, VxWorks, and QNX.

1.2 PCB View with Connectors

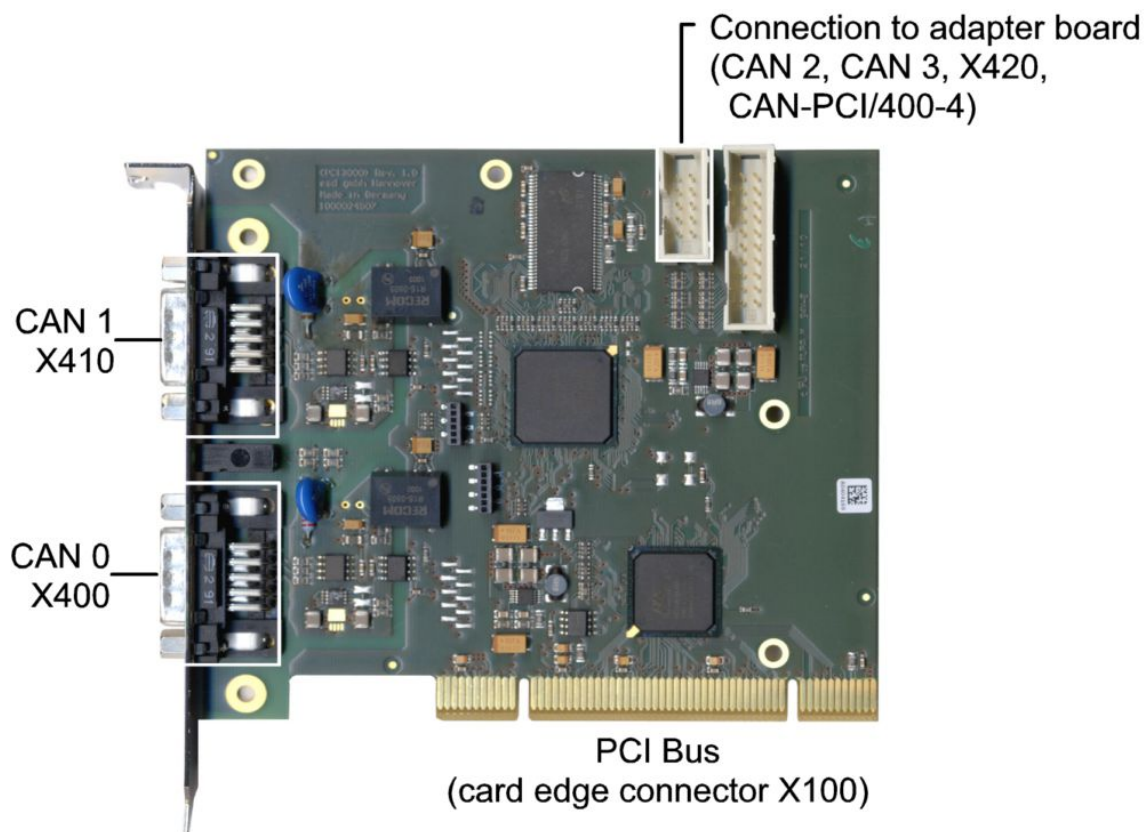

Figure 2: Top layer view of the CAN-PCI/400-2 with 2x CAN

See also page 17 for signal assignment of the CAN connectors.

2. Hardware Installation



NOTICE

Read the safety instructions at the beginning of this document carefully, before you start with the hardware installation!



DANGER

Hazardous Voltage - **Risk of electric shock** due to unintentional contact with uninsulated live parts with high voltages inside of the system into which the CAN-PCI/400 is to be integrated.

- Disconnect all hazardous voltages (mains voltage) before opening the system.
- Ensure the absence of voltage before starting any electrical work.



NOTICE

Electrostatic discharges may cause damage to electronic components.

- To avoid this, please discharge the static electricity from your body by touching the metal case of the PCI system *before* you touch the CAN-PCI/400.
- Furthermore, you should prevent your clothes from touching the CAN-PCI/400, because your clothes might be electrostatically charged as well.

Procedure:

1. Switch off your PCI system and all connected peripheral devices (monitor, printer, etc.).
Switch off the connected CAN devices
2. Discharge your body as described above.
3. Disconnect the power supply of the PC from the mains.



DANGER

Hazardous Voltage

Risk of electric shock due to unintentional contact with uninsulated live parts with high voltages.

- Disconnect all hazardous voltages (mains voltage) before opening the system.
- If the system does not have a flexible mains cable, but is directly connected to mains, disconnect the power supply via the safety fuse and make sure that the fuse cannot switch on again unintentionally (i.e. with caution label).
- Ensure the absence of voltage before starting any electrical work

4. Open the case.
5. Select an open PCI slot and remove the slot cover at the back of the PC.
The CAN module can be inserted into every PCI slot.



NOTICE

Be careful not to insert the board into an ISA slot, because this can damage the PC and the board!

6. Insert the CAN-PCI/400 board into the selected PCI slot. Carefully push the board down until it snaps into place.
7. Attach the board.
8. If you are installing the CAN-PCI/400-4 module with 4 CAN interfaces you have to install the adapter board in the PCI slot next to the CAN-PCI/400 board. Connect the two boards with the included ribbon cable (see figure 3 on page 12) via the 10-pin post connectors on the board and on the adapter.

9. Close the computer case again.
10. Connect the CAN wire.
Please note that the CAN bus has to be terminated at both ends!
Use the special T- connectors and terminator connectors offered by esd. Additionally the CAN_GND signal has to be connected to earth at exactly one point. For easier wiring the termination connectors are equipped with an earth connector (4.8 mm fast-on, male).
A CAN participant without an electrically isolated interface acts as an earth connection.

The first CAN interface (CAN 0) has to be connected via the lower DSUB connector (X400) and the second CAN interface (CAN 1) has to be connected via the upper DSUB connector (X410).

If you are installing a CAN-PCI/400-4 with four CAN interfaces, you have to connect the third CAN interface via the lower DSUB connector of the adapter board and the fourth CAN interface via the upper DSUB connector of the adapter board. You will find a figure showing the connectors on page 12.

11. Connect the system to mains again (mains connector or fuse).
12. Switch on the computer and the peripheral devices.
13. End of hardware installation.

Continue with the software installation as described in the manual 'NTCAN-API, Installation Guide'.

2.1 CAN-PCI/400-4 Version with 4 CAN Interfaces

CAN-PCI/400-4

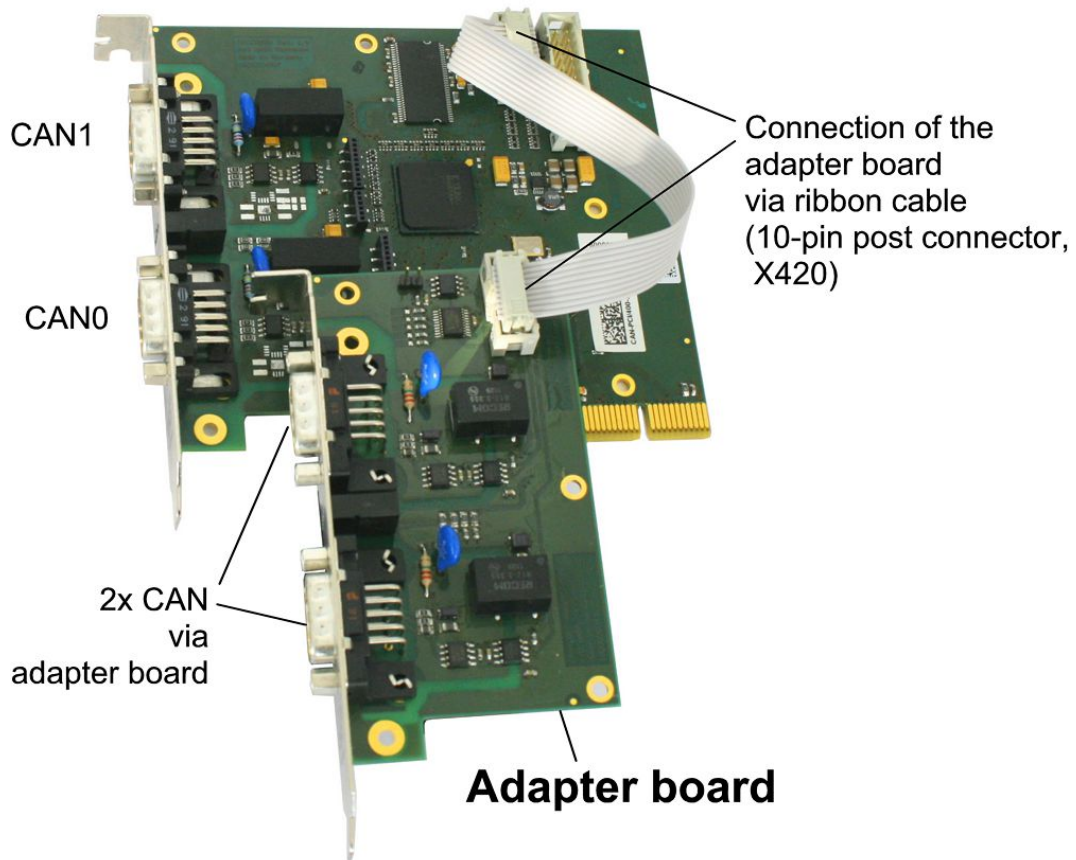

Figure 3: View of CAN-PCI/400-4 with ribbon cable

In the CAN-PCI/400-4 version, the board comes with four CAN interfaces. This module type uses two additional CAN transceivers. The physical layer of the additional CAN interfaces is placed on a separate adapter board. The adapter board has to be mounted close to the CAN-PCI/400. Furthermore, it has to be connected via the ribbon cable that is contained in the scope of delivery. The two additional physical interfaces are designed identical to the physical interfaces of CAN0 and CAN1.

3. Front Panel View with LED-Display

The CAN-PCI/400-2 is equipped with four green LEDs in the front panel.

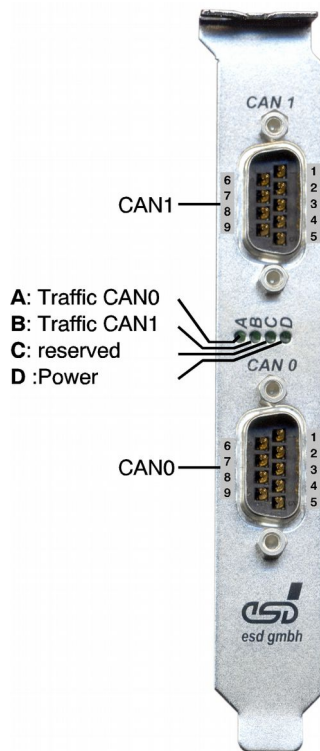

Figure 4: Front panel view (CAN-PCI/400-2)

Label	Name	Indicator State	Description	LED name in schematic diagram
A	Traffic CAN0	off	no CAN bus connection and/or no CAN traffic on CAN0	D300A
		on	connected to CAN bus 0 and CAN traffic on CAN0	
B	Traffic CAN1	off	no CAN bus connection and/or no CAN traffic on CAN1	D300B
		on	connected to CAN bus 1 and CAN traffic on CAN1	
C	reserved	-	-	D300C
D	Power	off	power supply voltage off	D300D
		on	power supply voltage on	

Table 1: LEDs

3.1 Additional LEDs on CAN-PCI/400-4 Adapter Board

The CAN-PCI/400-4 is equipped with four LEDs as described in table 1 and with four additional green LEDs in the front panel of the adapter board.

Label	Name	Indicator State	Description
A	Traffic CAN2	off	no CAN bus connection and/or no CAN traffic on CAN2
		on	connected to CAN bus 2 and CAN traffic on CAN2
B	Traffic CAN3	off	no CAN bus connection and/or no CAN traffic on CAN3
		on	connected to CAN bus 3 and CAN traffic on CAN3
C	reserved	-	-
D	Power	off	power supply voltage off
		on	power supply voltage on

Table 2: Additional LEDs on adapter board

4. Technical Data

4.1 General Technical Data

Ambient temperature	0...50°C
Humidity	90 %, non-condensing
Supply voltage	3.3 V \pm 5% / (depending on FPGA-image, 2x CAN: up to I = 1 A) and 5 V \pm 5% / 250 mA
Plug- and socket connectors	CAN0 - CAN interface 0 (9-pin DSUB/male, X400) CAN1 - CAN interface 1 (9-pin DSUB/male, X410) PCI-bus - (card edge connector, X100) X420 - connection to adapter board via ribbon cable (10-pin post connector) Only for test- and programming purposes: X200 - future use X430 - future use X700 - future use CAN-PCI/400-4 only (on adapter board): CAN0 - CAN interface 0 (9-pin DSUB/male) CAN1 - CAN interface 1 (9-pin DSUB/male) X420 - connection to CAN-PCI/400 board via ribbon cable (10-pin post connector)
LEDs	CAN traffic, Power
Dimensions	107 mm x 120 mm (board only) CAN-PCI/400-4 only: adapter board: 107 mm x 55 mm (board only)
Weight	CAN-PCI/400-2: 110 g CAN-PCI/400-4: 175 g

Table 3: General technical data of the module

4.2 PCI-Bus

Host bus	PCI bus according to PCI Local Bus Specification 2.2
PCI bus width	32 bit
PCI bus clock rate	33/66 MHz / 3.3 V signalling level (5.0 V tolerant)
Controller	PLX PCI9056
Interrupt	Interrupt Signal A
Slot position	no restrictions for the position of the CAN-PCI/400 on the PCI bus, PCI bridges are tolerated
Board dimensions	compatible with all 'short' PCI-card slots
Connector	PCI-card edge connector

Table 4: PCI bus data

4.3 CAN Interface

Number of CAN interfaces	CAN-PCI/400-2: 2 CAN high-speed interfaces (CAN0, CAN1) CAN-PCI/400-4: 4 CAN high-speed interfaces (CAN0, CAN1, CAN2, CAN3)
CAN controller	esdACC in FPGA Spartan®-3E, according to ISO11898-1 (CAN 2.0A/2.0B)
CAN protocol	according to ISO11898-1
Physical Layer	physical layer according to ISO 11898-2, bit rate up to 1 Mbit/s
Bus termination	terminating resistor has to be set externally, if required
Electrical isolation	via digital isolator and DC/DC-converters
Connector	CAN-PCI/400-2 (2x CAN): 2x DSUB9 (male) CAN-PCI/400-4 (4x CAN): 4x DSUB9 (male)

Table 5: Data of the CAN interface

4.4 Software Support

CAN layer 2 (NTCAN-API) software drivers are available for Windows, Linux, RTX, RTX64 VxWorks, QNX and OnTime RTOS-32.

The CANopen software package is available for Windows, Linux, VxWorks, and QNX.

Drivers for other operating systems are available on request.

For detailed information about the driver availability for your operating system, please contact our sales team: sales@esd.eu



INFORMATION

The CAN layer 2 (NTCAN-API) software installation and the software drivers are described in the NTCAN-API manual (esd-order No.: C.2001.21):

“NTCAN-API Part 1: Application Developers manual” and
“NTCAN-API Part 2: Installation Guide”

5. Connector Assignments

5.1 CAN

The signal assignments of CAN 0 and CAN 1 and both additional CAN interfaces (CAN-PCI/400-4 only) are identical.

Device connector: 9-pin DSUB connector, male

Pin Position:

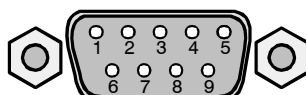

Pin Assignment:

Signal	Pin	Signal
(CANx_GND)	6	1 reserved
CANx_H		2 CANx_L
reserved	8	3 CANx_GND
reserved		4 reserved
	9	5 Shield

Signal Description:

CANx_L, CANx_H ... CAN signal lines of CAN net x (CAN-PCI/400-2: x ... 0,1,
CAN-PCI/400-4: x ... 0 - 3)

CANx_GND ... reference potential of the local CAN physical layer x
(CANx_GND)... optional reference potential of the local CAN physical layer
Shield ... shielding (connected with the case of the 9-pin DSUB connector)
reserved ... reserved for future applications, do not connect!

6. Correct Wiring of Electrically Isolated CAN Networks

For the CAN wiring all applicable rules and regulations (EU, DIN), e.g. regarding electromagnetic compatibility, security distances, cable cross-section or material, have to be observed.

6.1 Standards concerning CAN Wiring

The flexibility in CAN network design is one of the key strengths of the various extensions and additional standards like e.g. CANopen, ARINC825, DeviceNet and NMEA2000 that have been built on the original ISO 11898-2 CAN standard. In using this flexibility comes the responsibility of good network design and balancing these tradeoffs.

Many CAN organizations and standards have scaled the use of CAN for applications outside the original ISO 11898. They have made system level tradeoffs for data rate, cable length, and parasitic loading of the bus.

However for CAN network design margin must be given for signal loss across the complete system and cabling, parasitic loadings, network imbalances, ground offsets against earth potential and signal integrity. **Therefore the practical maximum number of nodes, bus length and stub length are typically much lower.**

esd has concentrated her recommendations concerning CAN wiring on the specifications of the ISO 11898-2. Thus this wiring hints forgoes to describe the special features of the derived standards CANopen, ARINC825, DeviceNet and NMEA2000.

The consistent compliance to ISO 11898-2 offers significant advantages:

- Durable operation due to well proven design specifications
- Minimizing potential failures due to sufficient margin to physical limits
- Trouble-free maintenance during future network modifications or during fault diagnostics due to lack of exceptions

Of course reliable networks can be designed according the specifications of CANopen, ARINC825, DeviceNet and NMEA2000, **however it must be observed that it is strictly not recommended to mix the wiring guidelines of the various specifications!**

6.2 Light Industrial Environment (*Single Twisted Pair Cable*)

6.2.1 General Rules



NOTICE

esd grants the EU Conformity of the product, if the CAN wiring is carried out with at least single shielded **single** twisted pair cables that match the requirements of ISO 11898-2. Single shielded *double* twisted pair cable wiring as described in chapter 6.3. ensures the EU Conformity as well.

The following **general rules** for CAN wiring with single shielded *single* twisted pair cable should be followed:

1	A cable type with a wave impedance of about $120\ \Omega \pm 10\%$ with an adequate conductor cross-section ($\geq 0.22\ \text{mm}^2$) has to be used. The voltage drop over the wire has to be considered.
2	For light industrial environment use at least a two-wire CAN cable. Connect <ul style="list-style-type: none"> • the two twisted wires to the data signals (CAN_H, CAN_L) and • the cable shield to the reference potential (CAN_GND).
3	The reference potential CAN_GND has to be connected to the functional earth (FE) at exactly one point.
4	A CAN net must not branch (exception: short cable stubs) and has to be terminated with the characteristic impedance of the line (generally $120\ \Omega \pm 10\%$) at both ends (between the signals CAN_L and CAN_H and not at CAN_GND).
5	Keep cable stubs as short as possible ($l < 0.3\ \text{m}$).
6	Select a working combination of bit rate and cable length.
7	Keep away cables from disturbing sources. If this cannot be avoided, double shielded wires are recommended.

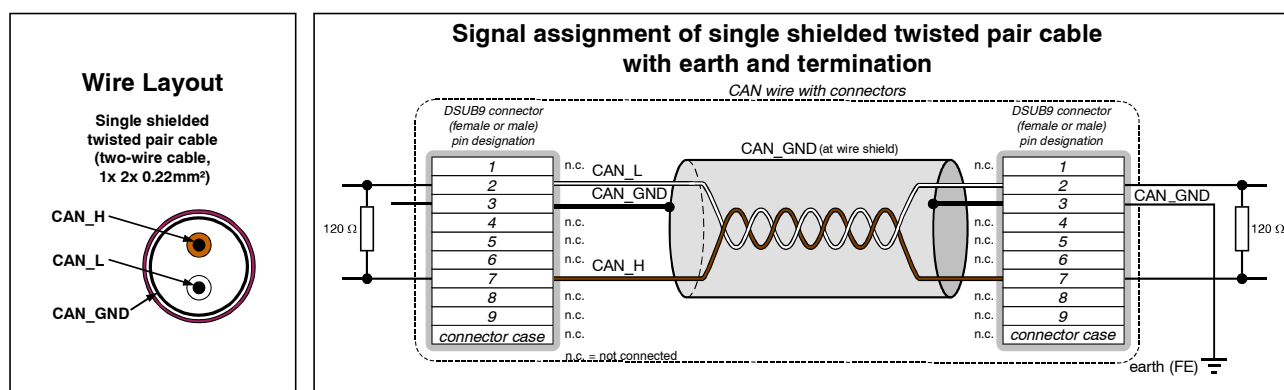

Figure 5: CAN wiring for light industrial environment

6.2.2 Cabling

- To connect CAN devices with just one CAN connector per net use a short stub (< 0.3 m) and a T-connector (available as accessory). If this devices are located at the end of the CAN network, the CAN terminator “CAN-Termination-DSUB9” can be used.

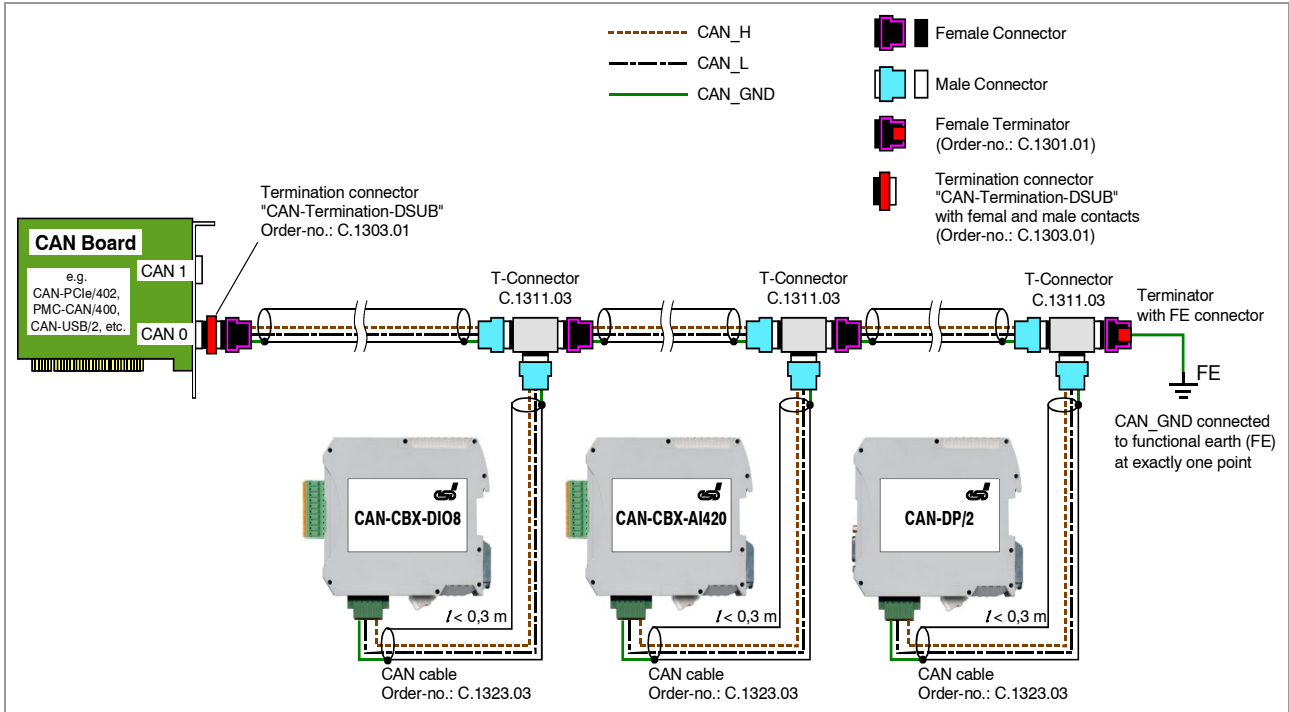

Figure 6: Example for proper wiring with single shielded single twisted pair wires

6.2.3 Termination

- A termination resistor has to be connected at both ends of the CAN bus. If an integrated CAN termination resistor which is equipped at the CAN interface at the end of the bus is connected, this one has to be used for termination instead of an external CAN termination plug.
- 9-pin DSUB-termination connectors with integrated termination resistor and male and female contacts (gender changer) are available from esd (order no. C.1303.01).
- DSUB termination connectors with male contacts (order no. C.1302.01) or female contacts (order no. C.1301.01) and additional functional earth contact are available, if CAN termination and grounding of CAN_GND is required.

6.3 Heavy Industrial Environment (*Double Twisted Pair Cable*)

6.3.1 General Rules

The following **general rules** for the CAN wiring with single shielded *double* twisted pair cable should be followed:

1	A cable type with a wave impedance of about $120\ \Omega \pm 10\%$ with an adequate conductor cross-section ($\geq 0.22\ \text{mm}^2$) has to be used. The voltage drop over the wire has to be considered.
2	For heavy industrial environment use a four-wire CAN cable. Connect <ul style="list-style-type: none"> • two twisted wires to the data signals (CAN_H, CAN_L) and • the other two twisted wires to the reference potential (CAN_GND) and • the cable shield to functional earth (FE) at least at one point.
3	The reference potential CAN_GND has to be connected to the functional earth (FE) at exactly one point.
4	A CAN bus line must not branch (exception: short cable stubs) and has to be terminated with the characteristic impedance of the line (generally $120\ \Omega \pm 10\%$) at both ends (between the signals CAN_L and CAN_H and not to CAN_GND).
5	Keep cable stubs as short as possible ($l < 0.3\ \text{m}$).
6	Select a working combination of bit rate and cable length.
7	Keep away CAN cables from disturbing sources. If this can not be avoided, double shielded cables are recommended.

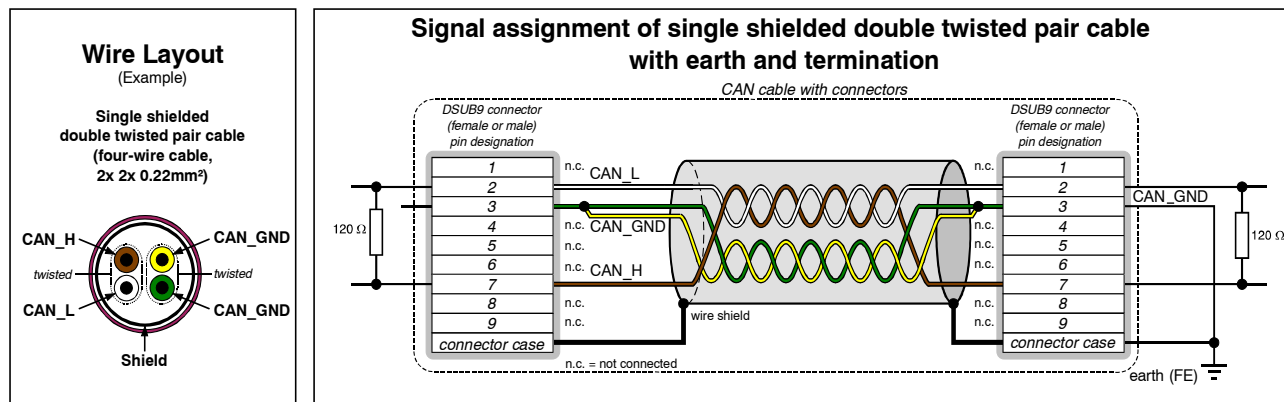

Figure 7: CAN wiring for heavy industrial environment

6.3.2 Device Cabling



NOTICE

If single shielded *double* twisted pair cables are used, realize the T-connections by means of connectors that support connection of two CAN cables at one connector where the cable's shield is looped through e.g. DSUB9 connector from ERNI (ERBIC CAN BUS MAX, order no.:154039).

The usage of esd's T-connector type C.1311.03 is not recommended for single shielded *double* twisted pair cables because the shield potential of the conductive DSUB housing is not looped through this T-connector type.

If a mixed application of single twisted and double twisted cables is unavoidable, take care that the CAN_GND line is not interrupted!

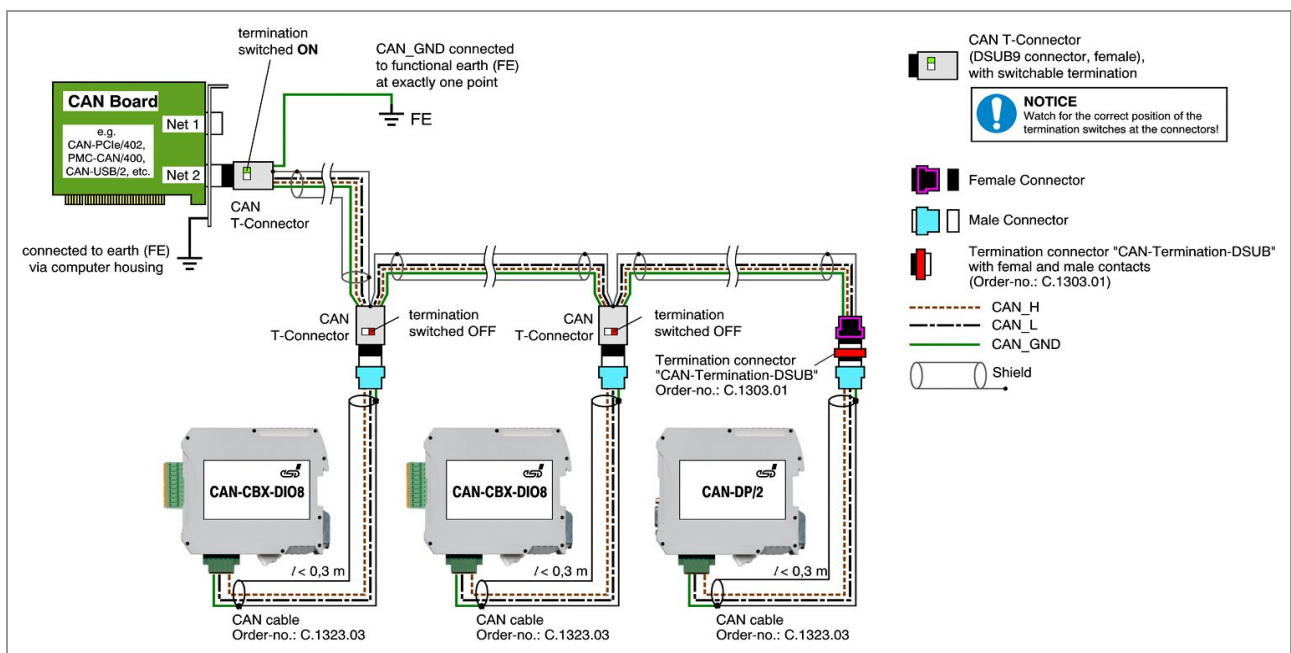

Figure 8: Example of proper wiring with single shielded double twisted pair cables

6.3.3 Termination

- A termination resistor has to be connected at both ends of the CAN bus. If an integrated CAN termination resistor which is equipped at the CAN interface at the end of the bus is connected, this one has to be used for termination instead of an external CAN termination plug.
- 9-pin DSUB-termination connectors with integrated termination resistor and male and female contacts (gender changer) are available from esd (order no. C.1303.01).
- 9-pin DSUB-connectors with integrated switchable termination resistor can be ordered e.g. from ERNI (ERBIC CAN BUS MAX, female contacts, order no.:154039).

6.4 Electrical Grounding

- For CAN devices with electrical isolation the CAN_GND must be connected between the CAN devices.
- CAN_GND should be connected to the earth potential (FE) at **exactly one** point of the network.
- Each *CAN interface with electrical connection to earth potential* acts as a grounding point. For this reason it is recommended not to connect more than one *CAN device with electrical connection to earth potential*.
- Grounding can be made e.g. at a termination connector (e.g. order no. C.1302.01 or C.1301.01).

6.5 Bus Length

Bit rate [Kbit/s]	Typical values of reachable wire length with esd interface I_{max} [m]	CiA recommendations (07/95) for reachable wire lengths I_{min} [m]
1000	37	25
800	59	50
666.6	80	-
500	130	100
333.3	180	-
250	270	250
166	420	-
125	570	500
100	710	650
83.3	850	-
66.6	1000	-
50	1400	1000
33.3	2000	-
20	3600	2500
12.5	5400	-
10	7300	5000

Table 6: Recommended cable lengths at typical bit rates (with esd-CAN interfaces)

- Optical couplers are delaying the CAN signals. esd modules typically reach a wire length of 37 m at 1 Mbit/s within a proper terminated CAN network without impedance disturbances like e.g. caused by cable stubs > 0.3 m.



NOTICE

Please note the recommendations of ISO 11898 regarding to the configuration of the cable cross-section in dependance of the cable length.

6.6 Examples for CAN Cables

esd recommends the following two-wire and four-wire cable types for CAN network design. These cable types are used by esd for ready-made CAN cables, too.

6.6.1 Cable for light industrial Environment Applications (Two-Wire)

Manufacturer	Cable Type
U.I. LAPP GmbH Schulze-Delitzsch-Straße 25 70565 Stuttgart Germany www.lappkabel.com	e.g. UNITRONIC ®-BUS CAN UL/CSA (1x 2x 0.22) (UL/CSA approved) Part No.: 2170260
	UNITRONIC ®-BUS-FD P CAN UL/CSA (1x 2x 0.25) (UL/CSA approved) Part No.: 2170272
ConCab GmbH Äußerer Eichwald 74535 Mainhardt Germany www.concab.de	e. g. BUS-PVC-C (1x 2x 0.22 mm ²) Order No.: 93 022 016 (UL appr.)
	BUS-Schleppflex-PUR-C (1x 2x 0.25 mm ²) Order No.: 94 025 016 (UL appr.)

6.6.2 Cable for heavy industrial Environment Applications (Four-Wire)

Manufacturer	Cable Type
U.I. LAPP GmbH Schulze-Delitzsch-Straße 25 70565 Stuttgart Germany www.lappkabel.com	e.g. UNITRONIC ®-BUS CAN UL/CSA (2x 2x 0.22) (UL/CSA approved) Part No.: 2170261
	UNITRONIC ®-BUS-FD P CAN UL/CSA (2x 2x 0.25) (UL/CSA approved) Part No.: 2170273
ConCab GmbH Äußerer Eichwald 74535 Mainhardt Germany www.concab.de	e. g. BUS-PVC-C (2x 2x 0.22 mm ²) Order No.: 93 022 026 (UL appr.)
	BUS-Schleppflex-PUR-C (2x 2x 0.25 mm ²) Order No.: 94 025 026 (UL appr.)



INFORMATION

Ready-made CAN cables with standard or custom length can be ordered from **esd**.

7. CAN Troubleshooting Guide

The CAN Troubleshooting Guide is a guide to find and eliminate the most frequent hardware-error causes in the wiring of CAN networks.

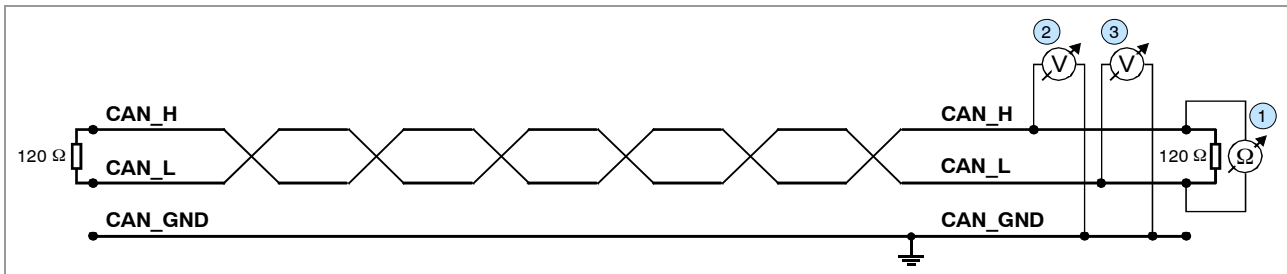

Figure 9: Simplified diagram of a CAN network

7.1 Termination

The termination is used to match impedance of a node to the impedance of the transmission line being used. When impedance is mismatched, the transmitted signal is not completely absorbed by the load and a portion is reflected back into the transmission line. If the source, transmission line and load impedance are equal these reflections are avoided. This test measures the series resistance of the CAN data pair conductors and the attached terminating resistors.

To test it ,please

1. Turn off all power supplies of the attached CAN nodes.
2. Measure the DC resistance between CAN_H and CAN_L at one end of the network ① (see figure above).

The measured value should be between 50 Ω and 70 Ω.

If the value is below 50 Ω, please make sure that:

- there is no **short circuit** between CAN_H and CAN_L wiring
- there are **not more than two** terminating resistors connected
- the nodes do not have faulty transceivers.

If the value is higher than 70 Ω, please make sure that:

- there are no open circuits in CAN_H or CAN_L wiring
- your bus system has two terminating resistors (one at each end) and that they are 120 Ω each.

7.2 Electrical Grounding

The CAN_GND of the CAN network should be connected to the functional earth potential (FE) at only **one** point. This test will check if the CAN_GND is grounded in several places.

To test it, please

1. Disconnect the CAN_GND from the earth potential (FE).
2. Measure the DC resistance between CAN_GND and earth potential (see figure on the right).
3. Reconnect CAN_GND to earth potential.

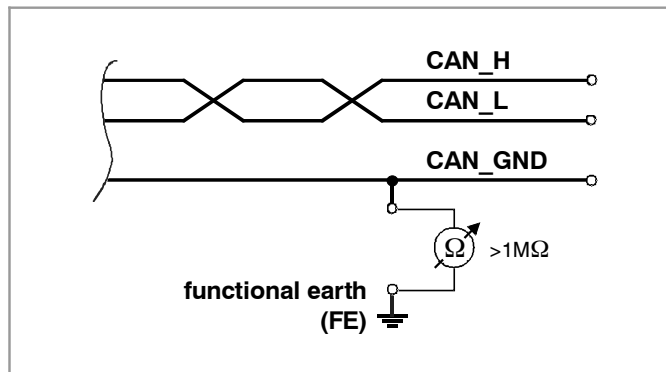

Figure 10: Simplified schematic diagram of ground test measurement

The measured resistance should be higher than 1 MΩ. If it is lower, please search for additional grounding of the CAN_GND wires.

7.3 Short Circuit in CAN Wiring

A CAN bus might possibly still be able to transmit data if there is a short circuit between CAN_GND and CAN_L, but generally the error rate will increase strongly. Make sure that there is no short circuit between CAN_GND and CAN_L!

7.4 CAN_H/CAN_L-Voltage

Each node contains a CAN transceiver that outputs differential signals. When the network communication is idle the CAN_H and CAN_L voltages are approximately 2.5 V measured to CAN_GND. Faulty transceivers can cause the idle voltages to vary and disrupt network communication.

To test for faulty transceivers, please

1. Turn on all supplies.
2. Stop all network communication.
3. Measure the DC voltage between CAN_H and CAN_GND ②
(see figure at previous page).
4. Measure the DC voltage between CAN_L and CAN_GND ③
(see figure at previous page).

Normally the voltage should be between 2.0 V and 3.0 V.

If it is lower than 2.0 V or higher than 3.0 V, it is possible that one or more nodes have faulty transceivers. For a voltage lower than 2.0 V please check CAN_H and CAN_L conductors for continuity.

To find the node with a faulty transceiver within a network please test the CAN transceiver resistance (see below) of the nodes.

7.5 CAN Transceiver Resistance Test

CAN transceivers have circuits that control CAN_H and CAN_L. Experience has shown that electrical damage of the circuits may increase the leakage current in these circuits.

To measure the current leakage through the CAN circuits, please use a resistance measuring device and:

1. Switch **off** the node and **disconnect** it from the network (4) (see figure below).
2. Measure the DC resistance between CAN_H and CAN_GND (5) (see figure below).
3. Measure the DC resistance between CAN_L and CAN_GND (6) (see figure below).

The measured resistance has to be about 500 k Ω for each signal. If it is much lower, the CAN transceiver it is probably faulty.

Another indication for a faulty transceiver is a very high deviation between the two measured input resistances (>> 200 %).

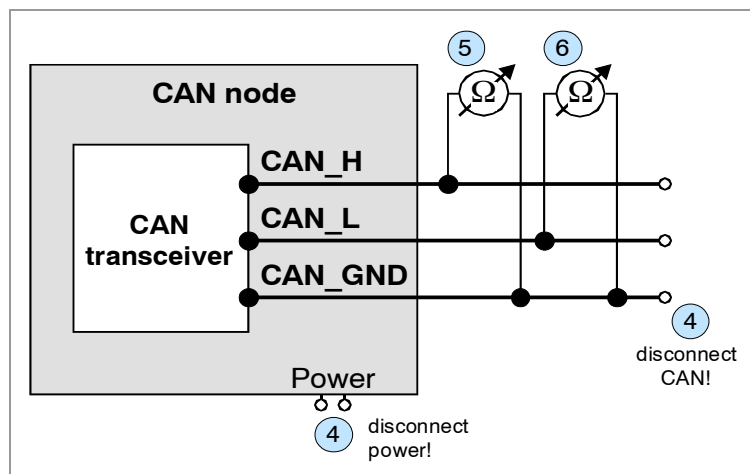

Figure 11: Measuring the internal resistance of CAN transceivers

7.6 Support by esd

If you have executed the fault diagnostic steps of this troubleshooting guide and you even can not find a solution for your problem our support department will be able to assist.

Please contact our support via email at support@esd.eu or by phone **+40-511-37298-130**.

8. Declaration of Conformity

EU-KONFORMITÄTSERKLÄRUNG EU DECLARATION OF CONFORMITY



Adresse **esd electronic system design gmbh**
Address **Vahrenwalder Str. 207**
30165 Hannover
Germany

esd erklärt, dass das Produkt
esd declares, that the product

CAN-PCI/400-2
CAN-PCI/400-4

Typ, Modell, Artikel-Nr.
Type, Model, Article No.

C.2048.04
C.2048.06

die Anforderungen der Normen
fulfills the requirements of the standards

EN 61000-6-2:2005,
EN 61000-6-3:2007/A1:2011

gemäß folgendem Prüfbericht erfüllt.
according to test certificate.

H-H00-0426-11,
H-Z01-0426-12

Das Produkt entspricht damit der EU-Richtlinie „EMV“
Therefore the product conforms to the EU Directive 'EMC'

2014/30/EU

Das Produkt entspricht der EU-Richtlinie „RoHS“
The product conforms to the EU Directive 'RoHS'

2011/65/EU

Diese Erklärung verliert ihre Gültigkeit, wenn das Produkt nicht den Herstellerunterlagen entsprechend eingesetzt und betrieben wird, oder das Produkt abweichend modifiziert wird.
This declaration loses its validity if the product is not used or run according to the manufacturer's documentation or if non-compliant modifications are made.

Name / Name T. Ramm
Funktion / Title CE-Koordinator / CE Coordinator
Datum / Date Hannover, 2015-11-16

Rechtsgültige Unterschrift / authorized signature

9. Order Information

Type	Properties	Order No.
CAN-PCI/400-2	2x CAN, ISO11898	C.2048.04
CAN-PCI/400-4	4x CAN, ISO 11898	C.2048.06
CAN layer 2 drivers for Windows and Linux are included in delivery.		
Software Drivers		
CAN-layer 2 object licences including CD-ROM: CAN-DRV-LCD QNX CAN-DRV-LCD VxWorks CAN-DRV-LCD RTX CAN-DRV-LCD OnTime-RTOS-32		C.1101.32 C.1101.55 C.1101.35 C.1101.45
CANopen object licences including CD-ROM: CANopen-DRV-LCD Windows/Linux CANopen-DRV-LCD QNX CANopen-DRV-LCD VxWorks CANopen-DRV-LCD RTX		C.1101.06 C.1101.17 C.1101.18 C.1101.16
J1939 Stack for esd CAN hardware: J1939 stack for Windows (object code) J1939 stack for Linux (object code) J1939 Stack for RTX (object code)		C.1130.10 C.1130.11 C.1130.12
ARINC825 object licenses including CD-ROM for esdACC based CAN interfaces: ARINC825-LCD Windows/Linux ARINC825-LCD RTX ARINC825-LCD QNX ARINC825-LCD VxWorks		C.1140.06 C.1140.16 C.1140.17 C.1140.18
For detailed information about the driver availability for your operating system, please contact our sales team.		

Table 7: Order information

PDF Manuals

Manuals are available in English and usually in German as well. For availability of English manuals see table below.

Please download the manuals as PDF documents from our esd website www.esd.eu for free.

Manuals	Order No.
CAN-PCI/400-ME Hardware manual in English	C.2048.21
CAN-API-ME NTCAN-API manual 1/2: Application Developers Manual NTCAN-API manual 2/2: Installation Guide	C.2001.21
CANopen-ME CANopen manuals in English	C.2002.21

Table 8: Available manuals

Printed Manuals

If you need a printout of the manual additionally, please contact our sales team: sales@esd.eu for a quotation. Printed manuals may be ordered for a fee.