

CAN-Control-I/O

64 Digital Inputs and 32 Digital Outputs

64 Digital Inputs

- 8 groups with 8 inputs each
- input voltage 24 V
- all inputs electrically isolated

32 Digital Outputs

- 4 groups with 8 outputs each
- 12 V or 24 V output voltage
- short circuit and overload protection
- driver supply voltage monitor with A/D conversion

CAN Interface

- 80C592 CAN controller
- CAN interface acc. to ISO11898

(This product is in life cycle stage end-of-life.)

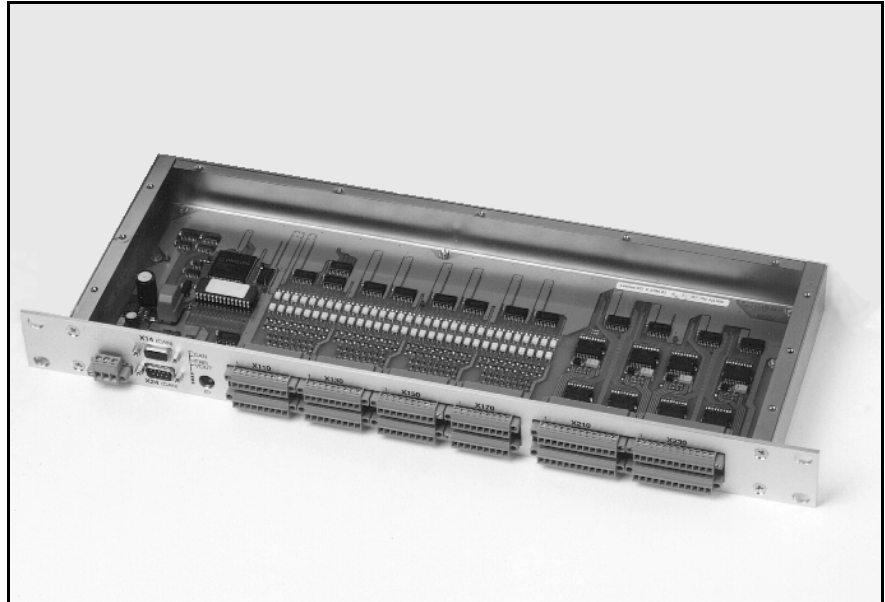

CAN-Control-I/O case with removed cover panel

CAN I/O in 19" Plug-In Case

The CAN-Control-I/O is a digital I/O module in a 19" plug-in case. The power supply is 24 V/DC. All connectors are accessible at the front panel.

CAN Interface

An 80C592 microcontroller is used to control the inputs and outputs. The program code is stored in a Flash EPROM and the parameters in an I²C EEPROM. As an option a SRAM is available.

The coding switch at the front panel is used to set a default value of the CAN identifier. The default bit rate can be set at a jumper field inside the case. Bit rates can be selected between 10 kbit/s and 1 Mbit/s.

The CAN interface is designed according to ISO11898. The CAN bus signals are not electrically isolated from the microcontroller.

Digital Inputs

The 64 inputs are designed for 24 V and can be connected via a combicon-style connector. Each 8 inputs use one GND. The inputs are electrically isolated.

Digital Outputs

The 32 digital outputs are designed to switch 24 V to GND. The outputs are protected against overtemperature and short circuit. An error message can be generated and send at the CAN bus.

The supply voltage of the output drivers is monitored by the analog inputs of the 80C592 microcontroller. The determined value can be read by CAN.

Software Support

The local software of the module supports the transparent reading of the inputs and the error status. Setting the outputs is possible by writing only one identifier.

Additionally, the software offers functions for the configuration of the module.

CAN-Control-I/O

64 Digital Inputs and 32 Digital Outputs

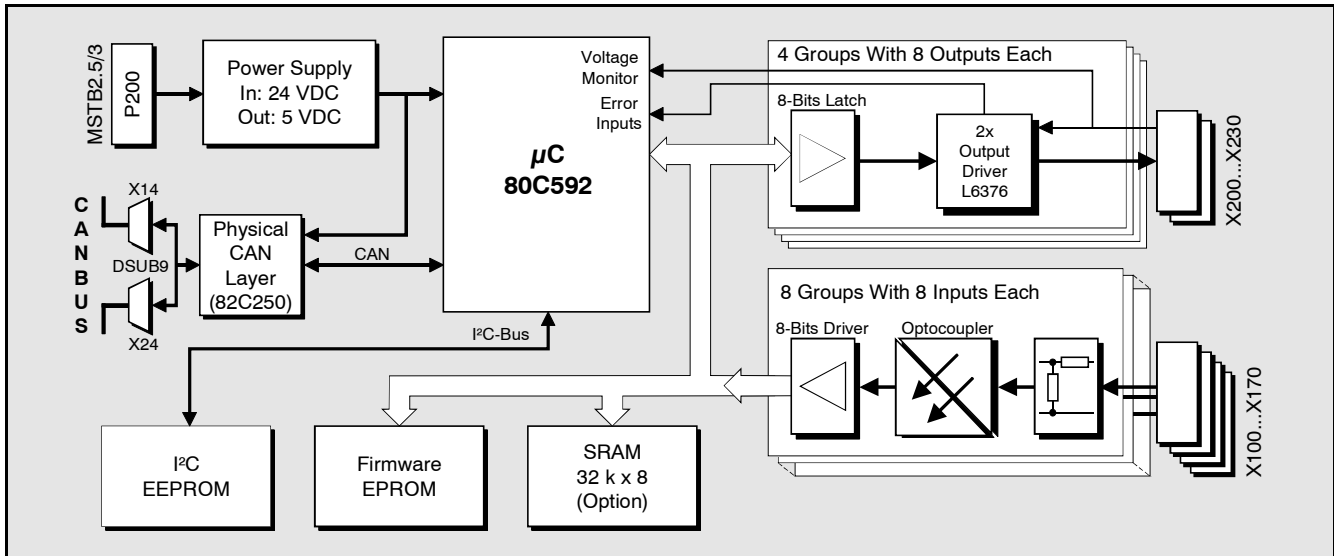

Technical Specifications:

Microcontroller and CAN section:

Microcontroller:	8xC592, 16 MHz
Memory:	Flash EPROM, I²C EEPROM, SRAM as an option
CAN interface:	acc. to ISO11898, no electrical isolation, bit rate up to 1 Mbit/s

Digital inputs:

Number:	64
Input voltage:	max. permissible: $-30\text{ V} \leq U_{IN} \leq 33\text{ V}$
Switching threshold:	'0': $U_{IN} < 9\text{ V}$, '1' $U_{IN} > 15\text{ V}$
Electrical isolation:	by optocouplers, each 8 inputs use one common GND

Digital outputs:

Number:	32, in groups with 8 outputs each
Driver supply voltage:	$U_{VCC} = 9.5\text{ V/DC} \dots 35\text{ V/DC}$
Load (24 V/50 °C):	0.65 A ... 1.2 A
Protection:	against short circuit and overload (thermal)
Error messages:	in case of over current, over temperature, low supply voltage

General:

Ambient temperature:	0...50 °C
Humidity:	max. 90 %, non-condensing
Connector types:	combicon-style connectors
Case dimensions:	19" x 1 HE x 250 mm
Power supply:	24 V/DC, approx. 1.5 W

Order information:

Designation		Order no.
CAN-Control-I/O	64 digital inputs, 32 digital outputs	C.2071.01
CAN-Control-I/O-CON	Set of connector plugs	C.2071.11
CAN-Control-I/O-ME	English users' manual	C.2071.21