

CANopen-DP/2

Gateway CANopen® to PROFIBUS-DP® Slave

Connection of CANopen Devices and Networks to PROFIBUS-DP

- PROFIBUS-DP slave acc. to IEC 61158 (240 bytes input and 240 bytes output)
- CANopen Manager
- Cycle time only limited by PROFIBUS-DP

Extendable with CANopen Modules via InRailBus

- Cable-free connection of esd CAN-CBX-I/O modules to the gateway
- InRailBus for CAN connection and power feed

Configuration with Standard Tools

- Run-time configuration via PLC
- No special tools required
- Plug 'n' play replacement

Linking PROFIBUS-DP and CANopen

The CANopen-DP/2 can link any PROFIBUS-DP master to a CANopen network. The gateway operates as a PROFIBUS-DP slave-I/O component



with a total of maximum 240 bytes input and 240 bytes output data. It supports cyclic (DP-V0) as well as acyclic (DP-V1) PROFIBUS data transfers.

On the CANopen side it operates as a CANopen manager supporting NMT master and configuration functions. PDO and SDO (with SDO timeout and MPDO transmission)

data transfers are supported. START frame, SYNC and Heartbeat are controlled by the module.

Applications

With the CANopen-DP/2 gateway you can couple CANopen modules e.g. to a SIMATIC-S7.

The number of CANopen devices is not limited by the module.

Physical Interfaces

The ISO 11898-compatible CAN interface allows a maximum data-transfer rate of 1 Mbit/s. The PROFIBUS-DP-Slave interface automatically recognizes all usual bit rates up to 12 Mbit/s.

The PROFIBUS-DP as well as the CAN interface are electrically isolated.

Configuration and CAN Protocols

The module can be configured via PROFIBUS configuration tool, e.g. the PLC SIMATIC Manager.

CANopen is supported as CAN-layer-7 protocol on the CAN layer. Additionally CAN-layer-2 functions are available.

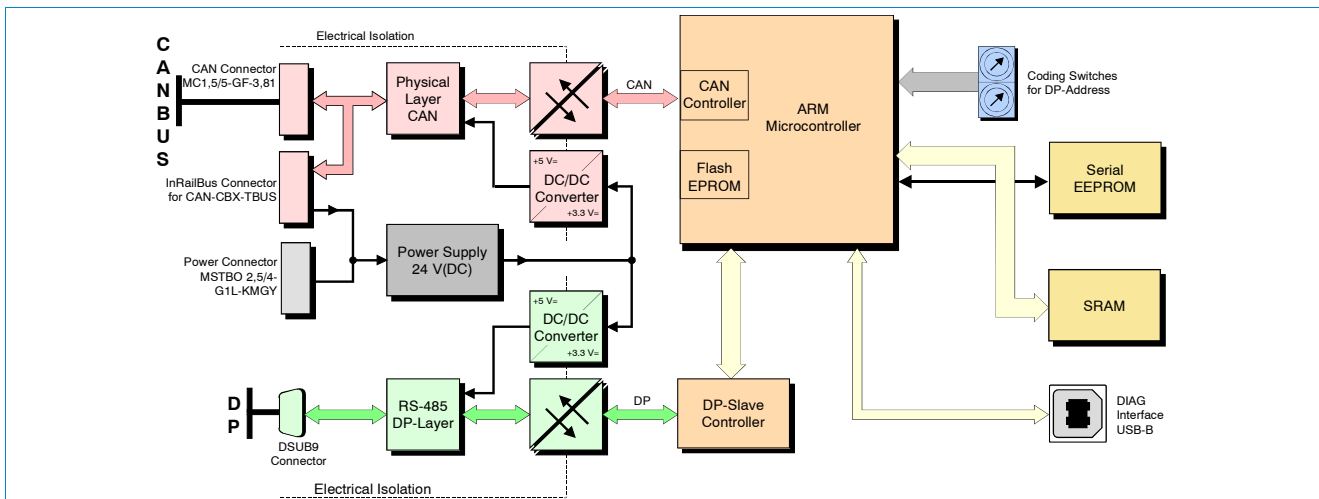

Technical Specifications:

CPU:	
Microcontroller	ARM®Cortex™-M3
Memory	SRAM: 1 MB Flash EPROM: 256 KB, integrated in microcontroller
CAN:	
CAN controller	ISO 11898-1, integrated in microcontroller
CAN interface	ISO 11898-2, electrically isolated, up to 1 Mbit/s
PROFIBUS-DP:	
DP controller	VPC3, PROFIBUS-DP Slave
DP interface	RS-485, electrically isolated, max. 12 Mbit/s

General :	
Operating voltage	Nominal 24 VDC ±20 %
Nominal current	55 mA @ 24 VDC
Ambient temp.	0 °C ... +55 °C
Relative humidity	Max. 90% (non-condensing)
Dimension	22.5 mm x 99 mm x 114.5 mm
Weight	ca. 125 g
Connectors	CAN: 5-pin Mini-Combicon or InRail Bus DP: 9-pin DSUB, female Power: 4-pin Combicon or InRailBus DIAG: USB type B connector (service only)

Order Information:	
Hardware	Order No.
CANopen-DP/2	Gateway CANopen to PROFIBUS-DP C.2909.02 slave, physical layer ISO 11898-2, firmware with gateway function, GSD-file included