

# CAN-CBX-REL4/2

## CANopen® Module with 2 Change-over and 2 Make Relay Contacts



### Switching Relays reliably via CANopen and CAN

- Switch loads easily as a change-over switch and normally open (make) contact
- Reliably switch up to 8 A up to 100,000 times
- Suitable for use in all areas with the wide temperature range from -20°C to +60°C

### CANopen® Integration according to CiA® Specifications

- Robust CANopen communication according to CiA specifications
- Compatibility and interoperability with CiA 301 CANopen application layer and communication profile ensured
- Generic I/O-module providing versatile integration capabilities with CiA 401 CANopen profile for I/O devices

### Extended Switching and Error Functions

- Simultaneous switching of up to 32 relays with one PDO / CAN frame
- Automatic switchover to the specified state in the event of system errors

### Easy to combine with other Modules of esd's CBX Series

- E.g. Modules for analog inputs or outputs.



### Reliable Relay Outputs

The CAN-CBX-REL4/2 is equipped with 4 relays which are electrically isolated from each other. Therefore, various voltages can be applied to the CAN-CBX-REL4/2 simultaneously.

### High-Speed CAN Interface

The module features a High-Speed CAN interface compliant with ISO11898 standards. It offers electrical isolation and supports bit rates up to 1 Mbit/s. CANopen node number and the CAN bit rate are configured conveniently via coding switches.

### Efficient I/O Integration

Within the CBX module series, the InRailBus technology offers compact industrial CAN input/output modules. These modules feature an efficient wiring concept for CAN and supply voltage and are housed in a slim design that focuses on usability.

### Advanced InRailBus Integration

The InRailBus connector (TBUS connector) simplifies the supply of power and CAN bus signals. It is seamlessly integrated into the DIN rail for user-friendly installation. At the same time, individual modules can be removed from the InRailBus without interrupting the bus signals, which enables efficient maintenance. Alternatively, power and signals can also be connected separately via the terminal connections.

### Comprehensive LED Status Display

Each relay has a dedicated LED that indicates the current state, while four additional LEDs clearly visualize the status of the CANopen node and I/O errors.

### Tailored Solutions upon Request

We offer customization options to meet your specific needs. For detailed information, kindly reach out to our sales team.

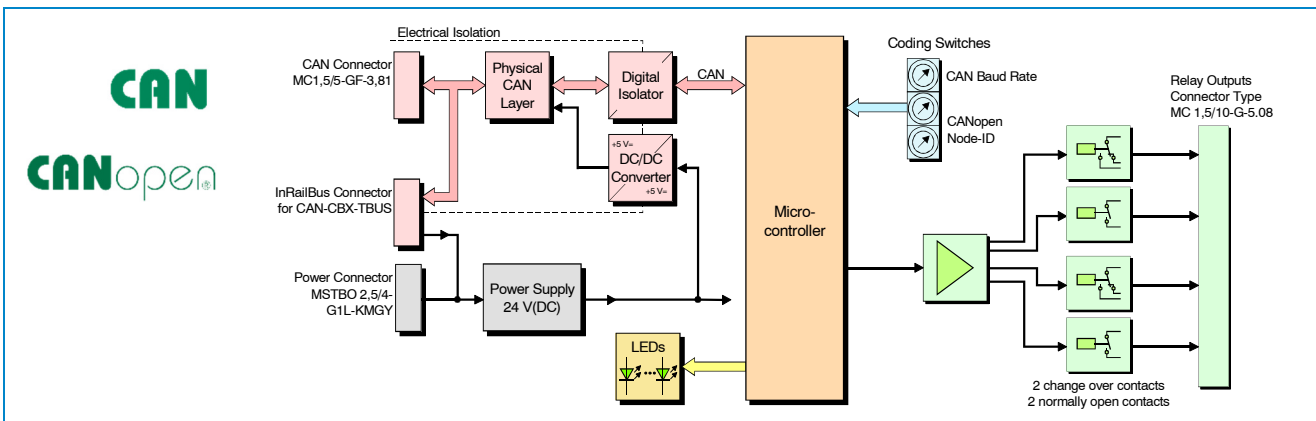

### Technical Specifications:

Relay Specification:		General	
Number of outputs	4 outputs: 2x normally open, 2x change-over	Power supply voltage	12 V DC... 32 V DC/ I <sub>MAX,24V</sub> = 100 mA
Switching voltage	Max. 250 V AC, 125 V DC	Ambient temperature	-20 °C ... +60 °C
Switching current	Max. 8 A (AC and DC)	Dimensions	22.5 mm x 99 mm x 114.5 mm (without connectors)
Switching power	Max. resistive load: 2000 VA/240 W Max. inductive load: 875 VA/170 W	Housing	Plastic housing (ME MAX) for carrier rail mounting NS 35/7,5 DIN EN 60715
Switching frequency	Max. 30 operations per minute	Protection class	IP20
Durability	Endurance mechanical load: 100 000 cycles	Connectors	Power: Phoenix MSTBO2,5/4-G1LKMGY CAN: Phoenix MC1,5/5-GF-3.81 Input: Phoenix MC 1,5/10-G-5,08
CAN:		Weight	Approximately 145 g
CAN interface	Physical layer according to ISO 11898-2, electrically isolated, CAN bit rate: 10 kbit/s up to 1 Mbit/s	<b>Order Information:</b>	
Protocol	CANopen according to CiA specifications CiA 301 and CiA 401	Hardware	Order No.
		CAN-CBX-REL4/2	CANopen module with 4 relay outputs C.3012.04
		<b>Accessories</b>	
		CAN-Cable-S 0.3m (plug) Cable, 0.3 m, pin contacts	C.1323.03
		CAN-CBX-TBus Mounting-rail bus connector	C.3000.01
		CAN-CBX-TBus-Connector-Socket	C.3000.02
		CAN-CBX-TBus-Connector-Plug	C.3000.03

**This product is under development. It will be available Q2 2024. All data specified here are preliminary and may be subject to change!**